



中国认可  
国际互认  
检测

TESTING  
CNAS L6791

Test Report issued under the responsibility of:



<b>TEST REPORT</b> <b>IEC 62109-1</b> <b>Safety of Power Converter for use in Photovoltaic Power Systems</b> <b>Part 1: General requirements</b>	
Report Number.....:	BL-DG2030075-B01
Date of issue.....:	May 25, 2020
Total number of pages.....:	71
Name of Testing Laboratory preparing the Report.....:	Shenzhen BALUN Technology Co., Ltd
Applicant's name.....:	Shenzhen SOFAR SOLAR Co., Ltd.
Address.....:	401, Building 4, AnTongDa Industrial Park, District 68, XingDong Community, XinAn Street, BaoAn District, Shenzhen, China.
<b>Test specification:</b>	
Standard.....:	IEC 62109- 1:2010 (First Edition)
Test procedure.....:	Commissioned test
Non-standard test method.....:	N/A
Test item description.....:	Hybrid Inverter
Trade Mark.....:	
Manufacturer.....:	Same as the applicant
Model/Type reference.....:	HYD 10KTL-3PH, HYD 15KTL-3PH, HYD 20KTL-3PH
Ratings.....:	See copy of marking label and model list.
Testing Laboratory.....:	Shenzhen BALUN Technology Co., Ltd
Testing location/ address 1 .....	Room 104, 204, 205, Building 1, No. 6, Industrial South Road, Songshan Lake District, Dongguan, Guangdong, China
Testing location/ address 2 .....	Block B, 1/F., Baisha Science & Technology Park, Shahe West Road, Nanshan District, Shenzhen, Guangdong, China
Tested by (name, function, signature).....:	Colin Chen /Engineer
Approved by (name, function, signature).....:	Simon Qi /Chief Engineer

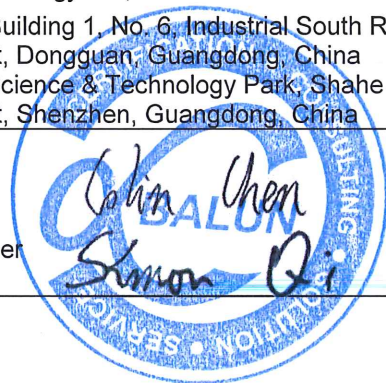

<p><b>List of Attachments (including a total number of pages in each attachment):</b>  ATTACHMENT 1 – Test report of IEC 62109-2: 2011 (1st Edition) (23 pages)  ATTACHMENT 2 – Photo documentation(8 pages)</p>	
<p><b>Summary of testing:</b></p>	
<p><b>Tests performed (name of test and test clause):</b>  4.2.2.6 Mains supply electrical data in normal condition  4.3 Thermal testing  4.4 Testing in fault condition  4.5 Humidity preconditioning  4.7 Electrical ratings tests  5.1.2 Durability of markings  6.3 Ingress protection  7.3.4.2.3 Access probe tests  7.3.5.3.2 Limitation of discharging energy through protective impedance  7.3.6.3 Protective class I - Protective bonding and earthing  7.3.7.4,7.3.7.5 Clearance and Creepage distances  7.3.9 Protection against shock hazard due to stored energy  7.4 Protection against energy hazards  7.5.1 Impulse voltage test  7.5.2 Voltage test (dielectric strength test)  7.5.4 Touch current measurement  8.2 Moving parts  8.3 Stability  8.4 Provisions for lifting and carrying  8.5 Wall mounting  9.1.3 Materials requirements for protection against fire hazard  10.2 Sonic pressure and sound level  13.1 Handles and manual controls  13.7 Mechanical resistance to deflection, impact or drop</p> <p>Remark:  - The max.operating temperature is 60°C specified by manufacturer, the temperature rise tests were conducted at the max.rated ambient temperature of 45°C or 60°C (derating) in the chamber.  - For the temperature rise tests were conducted on PCE power derating curve at most unfavourable operating conditions, see instruction manual for details.  - Other testing conditions considered in this test report, see General Product Information on the following pages.</p>	<p><b>Testing location:</b></p> <p>All tests except Ingress protection are performed at address 1 listed on page 1.  Ingress protection test is performed at address 2 listed on page 1</p>

**Summary of compliance with National Differences (List of countries addressed): None.**

**The product fulfils the requirements of IEC 62109-1: 2010, EN 62109-1: 2010, IEC 62109-2: 2011, EN 62109-2: 2011.**

**Copy of marking plate:**

The artwork below may be only a draft. The use of certification marks on a product must be authorized by the respective NCBs that own these marks.

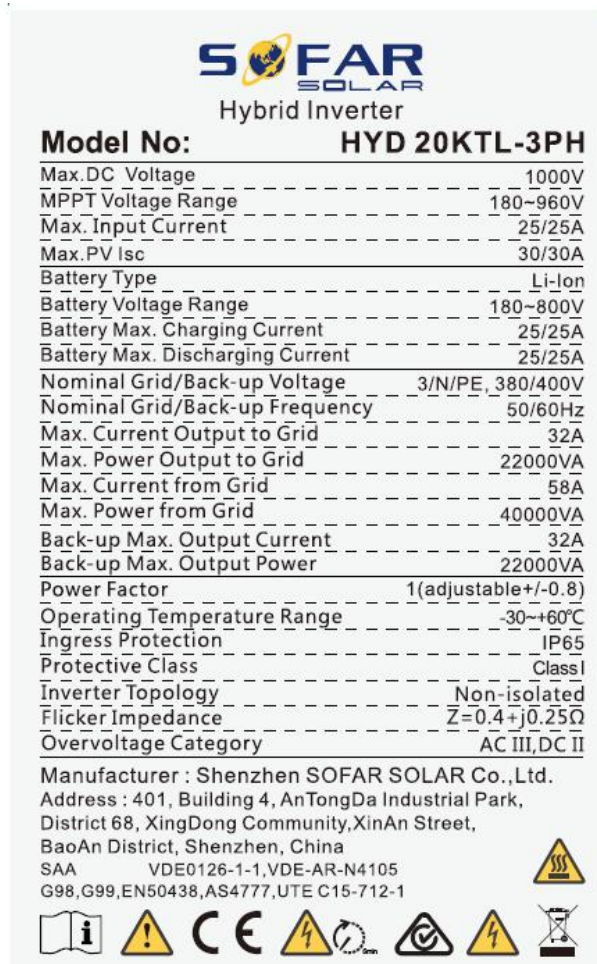

**Note:**

1. The above markings are the minimum requirements required by the safety standard. For the final production samples, the additional markings which do not give rise to misunderstanding may be added.
2. Label is attached on the side surface of enclosure and visible after installation
3. Labels of other models are as the same with HYD 20KTL-3PH's except the parameters of rating.

<b>Test item particulars</b> ..... :	
<b>Equipment mobility</b> ..... :	<input type="checkbox"/> movable <input type="checkbox"/> hand-held <input type="checkbox"/> stationary <input checked="" type="checkbox"/> fixed <input type="checkbox"/> transportable <input type="checkbox"/> for building-in
<b>Connection to the mains</b> ..... :	<input type="checkbox"/> pluggable equipment <input type="checkbox"/> direct plug-in <input checked="" type="checkbox"/> permanent connection <input type="checkbox"/> for building-in
<b>Environmental category</b> ..... :	<input checked="" type="checkbox"/> outdoor <input type="checkbox"/> indoor unconditional <input type="checkbox"/> indoor conditional
<b>Over voltage category Mains</b> ..... :	<input type="checkbox"/> OVC I <input type="checkbox"/> OVC II <input checked="" type="checkbox"/> OVC III <input type="checkbox"/> OVC IV
<b>Over voltage category PV</b> ..... :	<input type="checkbox"/> OVC I <input checked="" type="checkbox"/> OVC II <input type="checkbox"/> OVC III <input type="checkbox"/> OVC IV
<b>Mains supply tolerance (%)</b> ..... :	According to the specified supply range.
<b>Tested for power systems</b> ..... :	TN
<b>IT testing, phase-phase voltage (V)</b> ..... :	N/A
<b>Class of equipment</b> ..... :	<input checked="" type="checkbox"/> Class I <input type="checkbox"/> Class II <input type="checkbox"/> Class III <input type="checkbox"/> Not classified
<b>Mass of equipment (kg)</b> ..... :	37
<b>Pollution degree</b> ..... :	PD3(Inside PD2)
<b>IP protection class</b> ..... :	IP65
..... :	
<b>Possible test case verdicts:</b>	
- test case does not apply to the test object..... : N/A	
- test object does meet the requirement..... : P (Pass)	
- test object was not evaluated for the requirement..... : N/E	
- test object does not meet the requirement..... : F (Fail)	
<b>Testing</b> ..... :	
<b>Date of receipt of test item</b> ..... :	Mar. 23, 2020
<b>Date (s) of performance of tests</b> ..... :	Mar. 23, 2020 to Apr. 20, 2020

<b>General remarks:</b>			
<p>"(See Enclosure #)" refers to additional information appended to the report.          "(See appended table)" refers to a table appended to the report.          The tests results presented in this report relate only to the object tested.          This report shall not be reproduced except in full without the written approval of the testing laboratory.          List of test equipment must be kept on file and available for review.          Additional test data and/or information provided in the attachments to this report.  <b>Throughout this report a <input type="checkbox"/> comma / <input checked="" type="checkbox"/> point is used as the decimal separator.</b>          Determination of the test results includes consideration of measurement uncertainty from the test equipment and methods.</p>			
<b>Manufacturer's Declaration per sub-clause 4.2.5 of IEC 62109-1:</b>			
The application for obtaining a CB Test Certificate includes more than one factory location and a declaration from the Manufacturer stating that the sample(s) submitted for evaluation is (are) representative of the products from each factory has been provided.....:	<input type="checkbox"/> <b>Yes</b> <input checked="" type="checkbox"/> <b>Not applicable</b>		
<b>When differences exist; they shall be identified in the General product information section.</b>			
<b>Name and address of factory (ies)..... :</b> <div style="text-align: right; padding-right: 50px;">                     Dongguan SOFAR SOLAR Co., Ltd.                      1F - 6F, Building E, No. 1 JinQi Road, Bihu Industrial Park, Wulian Village, Fenggang Town, Dongguan City.                 </div>			
<b>General product information:</b>			
<u>Brief description:</u>			
The PCE under test (EUT) is Hybrid Inverter. During inverter, which convert the variable DC power generated from the photovoltaic (PV) arrays and Batteries to the stable utility AC power which can be fed into the commercial electrical grid. When charging, the grid converts the alternating current into direct current into the battery through the Hybrid Inverter.			
The PCE under test is three-phase Hybrid Inverter for solar power generation with the rating of 10kW, 15kW and 20kW.			
The external circuit breakers or fuses for PV array, Batteries and Grid connection are required which the statements are provided in the installation manual.			
The models of HYD 10KTL-3PH, HYD 15KTL-3PH, and HYD 20KTL-3PH are identical on topological schematic circuit diagram and control solution codes. The difference between each other as following table:			
	Model		
Item	HYD 20KTL-3PH	HYD 15KTL-3PH	HYD 10KTL-3PH
Recommended Max.PV Power	30000Wp (15000Wp/15000Wp)	22500 Wp (11250Wp /11250Wp)	15000Wp (7500Wp /7500Wp)
Full power MPPT voltage	450V~850V	350V~850V	220V~850V

range			
Battery Voltage Range for Full Load	400V~800V	300V~800V	200V~800V
Max. charging/discharging power	20000W	15000W	10000W
Nominal AC Power	20000W	15000W	10000W
Max. AC Power Output to Utility Grid	22000VA	16500VA	11000VA
Max. AC Power from Utility Grid	40000VA	30000VA	20000VA
Max. AC Current Output to Utility Grid	32A	24A	16A
Max. AC Current from Utility Grid	58A	44A	29A
Max. output power	22000VA	16500VA	11000VA
Inverter inductance	0.876 mH		1.12 mH

Unless otherwise specified, all the tests were conducted on the basic model of HYD 20KTL-3PH.

The PCE does not provide galvanic separation between the PV array, Batteries and Grid connection circuit (Non-isolation or transformer-less type).

The Grid connection circuit can be switched off by two relays in series for the redundant protection. When single-fault occurs to one relay, the other redundant one will still maintain the basic insulation between PV array, Batteries and Grid connection to the mains. All the relays have functional self-checking before the PCE starting.

**Block Diagram:**

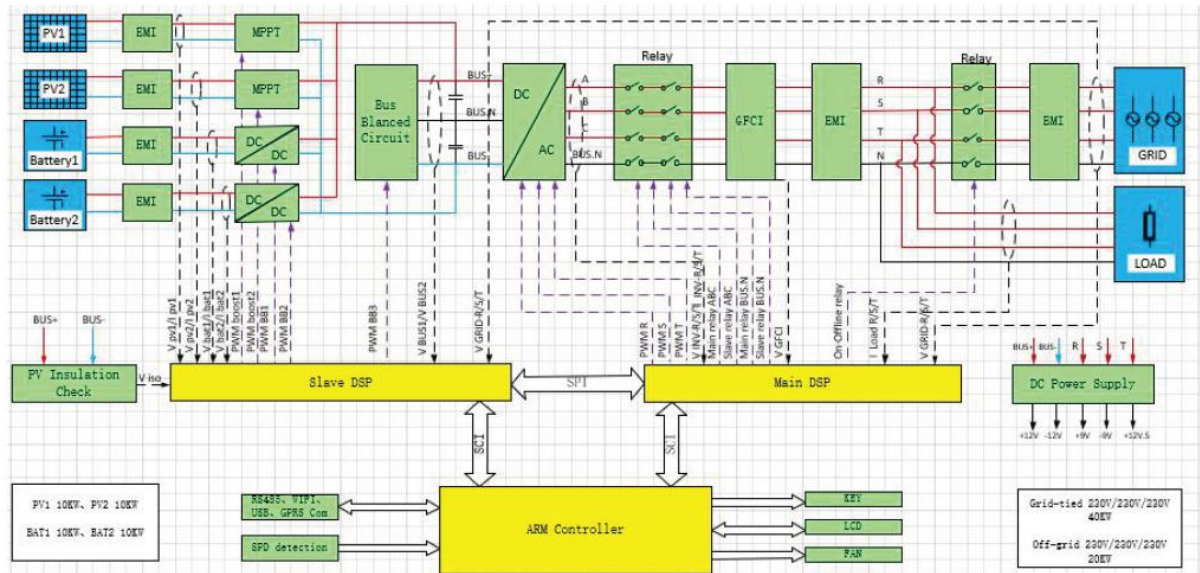

Throughout the test report following abbreviations may be used:

- input	i/p	- Test repeated, similar result(3 times)	TRSR
- output	o/p	- No indication of dielectric breakdown	NB
- short-circuited	s-c	- Cheesecloth remained intact	NC
- overloaded	o-l	- Tissue paper remained intact	NT
- open-circuited	o-c	- No hazards	NH
- normal conditions	N.C.	- The PCE can recover to operate automatically after removing the abnormal condition	RO
- single fault conditions	SFC	- functional insulation	FI
- between parts of opposite polarity	BOP	- basic insulation	BI
- internal protection operated	IPO	- supplementary insulation	SI
- Component damage (list damaged component)	CD	- double insulation	DI
- No component damaged	NCD	- reinforced insulation	RI
- Power Conversion Equipment Indicate used abbreviations (if any)	PCE	- Equipment Under Test	EUT



IEC 62109-1			
Clause	Requirement – Test	Result – Remark	Verdict
<b>4</b>	<b>GENERAL TESTING REQUIREMENTS</b>		P
4.1	General		P
4.2	General conditions for testing		P
4.2.1	Sequence of tests		P
4.2.2	Reference test conditions		P
4.2.2.1	Environmental conditions	Ambient environmental condition compliance.	P
4.2.2.2	State of equipment	Test carried on a complete EUT.	P
4.2.2.3	Position of equipment	The equipment was installed in accordance with the manufacturer's instructions.	P
4.2.2.4	Accessories	Accessories and operator-interchangeable parts available from, or recommended by the manufacturer according to the installation manual required.	P
4.2.2.5	Covers and removable parts	No covers or parts, which can be removed without using a TOOL.	N/A
4.2.2.6	Mains supply a) Voltage: b) Frequency: c) Polarity: d) Earthing: e) Over-current Protection:	(see appended table 4.2.2.6)	P
4.2.2.7	Supply ports other than the mains		P
4.2.2.7.1	Photovoltaic supply sources a) Open circuit voltage: b) Short-circuit current:	(see appended table 4.2.2.7)	P
4.2.2.7.2	Battery inputs	(see appended table 4.2.2.7)	P
4.2.2.8	Conditions of loading for output ports	The least favorable loading conditions was considered. Until steady condition was established.	P
4.2.2.9	Earthing terminals	Connection to the earth	P
4.2.2.10	Controls	Any position was set.	P
4.2.2.11	Available short circuit current	Considered.	P
4.3	Thermal testing	(see appended table 4.3)	P

IEC 62109-1			
Clause	Requirement – Test	Result – Remark	Verdict
4.3.1	General		P
4.3.2	Maximum temperatures		P
4.3.2.1	General		P
4.3.2.2	Touch temperatures		P
4.3.2.3	Temperature limits for mounting surfaces		P
4.4	Testing in single fault condition	(see appended table 4.4)	P
4.4.1	General		P
4.4.2	Test conditions and duration for testing under fault conditions		P
4.4.2.1	General		P
4.4.2.2	Duration of tests		P
4.4.3	Pass/fail criteria for testing under fault conditions		P
4.4.3.1	Protection against shock hazard		P
4.4.3.2	Protection against the spread of fire		P
4.4.3.3	Protection against other hazards		P
4.4.3.4	Protection against parts expulsion hazards		P
4.4.4	Single fault conditions to be applied	See below.	P
4.4.4.1	Component fault tests	(see appended table 4.4)	P
4.4.4.2	Equipment or parts for short-term or intermittent operation	Continuous operation equipment.	N/A
4.4.4.3	Motors	Not used.	N/A
4.4.4.4	Transformer short circuit tests	(see appended table 4.4)	P
4.4.4.5	Output short circuit	(see appended table 4.4)	P
4.4.4.6	Backfeed current test for equipment with more than one source of supply	Considered	P
4.4.4.7	Output overload	(see appended table 4.4)	P
4.4.4.8	Cooling system failure	(see appended table 4.4)	P
4.4.4.9	Heating devices	No heating devices used.	N/A
4.4.4.10	Safety interlock systems	No safety interlock device used.	N/A
4.4.4.11	Reverse d.c. connections	(see appended table 4.4)	P
4.4.4.12	Voltage selector mismatch	No voltage selector used.	N/A
4.4.4.13	Mis-wiring with incorrect phase sequence or polarity	DC mains supply.	N/A
4.4.4.14	Printed wiring board short-circuit test	(see appended table 4.4)	P
4.5	Humidity preconditioning	(see appended table 7.5)	P

<b>IEC 62109-1</b>			
Clause	Requirement – Test	Result – Remark	Verdict
4.5.1	General		P
4.5.2	Conditions	Humidity: 93%RH Temperature: 40°C Duration: 48hrs	P
4.6	Backfeed voltage protection	Hazardous voltage and energy was not present on the terminals, with the DC mains supply source de-energized or disconnected. In addition the symbol 13 of Table C.1 was marked for servicing functions	P
4.6.1	Backfeed tests under normal conditions	Relay or Contactor is available at AC output side to prevent back-feed current from AC to DC side.	P
4.6.2	Backfeed tests under single-fault conditions	Relay or contactor is available at AC output side and with auto disconnected device at DC input side to prevent backfeed current from AC to DC side, even if under single-fault conditions.	P
4.6.3	Compliance with backfeed tests	See above.	N/A
4.7	Electrical ratings tests	(see appended table 4.2.2.6)	P
4.7.1	Input ratings		P
4.7.1.1	Measurement requirements for DC input ports		P
4.7.2	Output ratings		P
<b>5</b>	<b>MARKING AND DOCUMENTATION</b>		P
5.1	Marking		P
5.1.1	General		P
	Equipment shall bear markings as specified in 5.1 and 5.2	The marking label is on the outer surface of the enclosure.	P
	Graphic symbols may be used and shall be in accordance with Annex C or IEC 60417 as applicable.	All used graphic symbols are in accordance with Annex C.	P
	Graphic symbols shall be explained in the documentation provided with the PCE.	The explanations are provided in the user manual.	P
5.1.2	Durability of markings	The labels were subjected to the permanence of marking	P
	Markings required by this clause to be located on the PCE shall remain clear and legible under conditions of NORMAL USE and resist the effects of cleaning agents specified by the manufacturer	After this test there was no damage to the labels. The marking on the labels did not fade. There was no curling or	P

IEC 62109-1			
Clause	Requirement – Test	Result – Remark	Verdict
		lifting of the label's edges.	
5.1.3	Identification		P
	The equipment shall, as a minimum, be permanently marked with:	See below.	P
	a) the name or trade mark of the manufacturer or supplier	See copy of marking plate.	P
	b) model number, name or other means to identify the equipment	See above.	P
	c) a serial number, code or other marking allowing identification of manufacturing location and the manufacturing batch or date within a three month time period.	See above.	P
5.1.4	Equipment ratings		P
	Unless otherwise specified in another part of IEC 62109, the following ratings, as applicable shall be marked on the equipment:	See below	P
	– input voltage, type of voltage (a.c. or d.c.), frequency, and max. continuous current for each input	See model list.	P
	– output voltage, type of voltage (a.c. or d.c.), frequency, max. continuous current, and for a.c. outputs, either the power or power factor for each output	See above.	P
	– the ingress protection (IP) rating as in 6.3 below	See clause 6.3	P
5.1.5	Fuse identification		P
	Marking shall be located adjacent to each fuse or fuseholder, or on the fuseholder, or in another location provided that it is obvious to which fuse the marking applies, giving the fuse current rating and where fuses of different voltage rating value could be fitted, the fuse voltage rating.	Marking on PCB near fuses.	P
	Where fuses with special fusing characteristics such as time delay or breaking capacity are necessary, the type shall also be indicated	See above.	P
	For fuses not located in operator access areas and for soldered-in fuses located in operator access areas, it is permitted to provide an unambiguous cross-reference (for example, F1, F2, etc.) to the servicing instructions which shall contain the relevant information.	See above.	P
5.1.6	Terminals, Connections, and Controls		P
	If necessary for safety, an indication shall be given of the purpose of Terminals, connectors, controls, and indicators, and their various positions, including any connections for coolant fluids such as water	Relevant symbol, indicator or information are available.	P

IEC 62109-1			
Clause	Requirement – Test	Result – Remark	Verdict
	and drainage. The symbols in Annex C may be used, and where there is insufficient space, symbol 9 of Annex C may be used.		
	Push-buttons and actuators of emergency stop devices, and indicator lamps used only to indicate a warning of danger or the need for urgent action shall be coloured red.	No such device.	N/A
	A multiple-voltage unit shall be marked to indicate the particular voltage for which it is set when shipped from the factory. The marking is allowed to be in the form of a paper tag or any other non-permanent material.		N/A
	A unit with d.c. terminals shall be plainly marked indicating the polarity of the connections, with:		P
	– the sign “+” for positive and “-”, for negative; or	The “+” and “-“ marking provided adjacent to the PV input connectors.	P
	– a pictorial representation illustrating the proper polarity where the correct polarity can be unambiguously determined from the representation	No pictorial representation illustration used.	N/A
5.1.6.1	Protective Conductor Terminals		P
	The means of connection for the protective earthing conductor shall be marked with:		P
	– symbol 7 of Annex C; or	Symbol 7 of Table C.1 marked adjacent to the PE terminal.	P
	– the letters “PE“; or	See above.	N/A
	– the colour coding green-yellow.		P
5.1.7	Switches and circuit-breakers		P
	The on and off-positions of switches and circuits breakers shall be clearly marked. If a push-button switch is used as the power switch, symbols 10 and 16 of Annex C may be used to indicate the on-position, or symbols 11 and 17 to indicate the off-position, with the pair of symbols (10 and 16, or 11 and 17) close together.	The letter “ON” and “OFF” is clearly marked.	P
5.1.8	Class II Equipment	Class I Equipment.	N/A
	Equipment using Class II protective means throughout shall be marked with symbol 12 of Annex C. Equipment which is only partially protected by DOUBLE INSULATION or REINFORCED INSULATION shall not bear symbol 12 of Table Annex C.	See above.	N/A
	Where such equipment has provision for the connection of an earthing conductor for functional	See above.	N/A

IEC 62109-1			
Clause	Requirement – Test	Result – Remark	Verdict
	reasons (see 7.3.6.4) it shall be marked with symbol 6 of Annex C		
5.1.9	Terminal boxes for External Connections		N/A
	Where required by note 1 of Table 2 as a result of high temperatures of terminals or parts in the wiring compartment, there shall be a marking, visible beside the terminal before connection, of either:	Not used.	N/A
	a) the minimum temperature Rating and size of the cable to be connected to the TERMINALS; or		N/A
	b) a marking to warn the installer to consult the installation instruction. Symbol 9 of Table D-1 is an acceptable marking		N/A
5.2	Warning markings		P
5.2.1	Visibility and legibility requirements for warning markings		P
	Warning markings shall be legible, and shall have minimum dimensions as follows:		P
	– Printed symbols shall be at least 2,75 mm high		P
	– Printed text characters shall be at least 1.5 mm high and shall contrast in colour with the background		P
	– Symbols or text that are moulded, stamped or engraved in a material shall have a character height of at least 2,0 mm, and if not contrasting in colour from the background, shall have a depth or raised height of at least 0,5 mm.	No such symbols.	N/A
	If it is necessary to refer to the instruction manual to preserve the protection afforded by the equipment, the equipment shall be marked with symbol 9 of Annex C		P
	Symbol 9 of Annex C is not required to be used adjacent to symbols that are explained in the manual		P
5.2.2	Content for warning markings		P
5.2.2.1	Ungrounded heat sinks and similar parts		P
	An ungrounded heat sink or other part that may be mistaken for a grounded part and involves a risk of electric shock in accordance with 7.3 shall be marked with symbol 13 of Annex C, or equivalent. The marking may be on or adjacent to the heat sink and shall be clearly visible when the PCE is disassembled to the extent that a risk of contact with the heat sink exists.	Marked with symbol 13 of Table C.1.	P



IEC 62109-1			
Clause	Requirement – Test	Result – Remark	Verdict
5.2.2.2	Hot Surfaces		P
	A part of the PCE that exceeds the temperature limits specified in 4.3.2 shall be marked with symbol 14 of Annex C or equivalent.	Marked with symbol 14 of Table C.1.	P
5.2.2.3	Coolant		N/A
	A unit containing coolant that exceeds 70 °C shall be legibly marked externally where readily visible after installation with symbol 15 of Annex C. The documentation shall provide a warning regarding the risk of burns from hot coolant, and either:	Not used.	N/A
	a) statement that coolant system servicing is to be done only by SERVICE PERSONNEL, or		N/A
	b) instructions for safe venting, draining, or otherwise working on the cooling system, if these operations can be performed without OPERATOR access to HAZARDS internal to the equipment		N/A
5.2.2.4	Stored energy		P
	Where required by 7.3.9.2 or 7.4.2 the PCE shall be marked with Symbol 21 of Annex C and the time to discharge capacitors to safe voltage and energy levels shall accompany the symbol.	Marked with Symbol 21 of Table C.1 and the time to discharge capacitors to safe voltage and energy levels accompany the symbol.	P
5.2.2.5	Motor guarding		N/A
	Where required by 8.2 a marking shall be provided where it is visible to service personnel before removal of a guard, warning of the hazard and giving instructions for safe servicing (for example disconnection of the source before removing the guard).		N/A
5.2.3	Sonic hazard markings and instructions	No such hazard.	N/A
	If required by 10.2.1 a PCE shall:		N/A
	a) be marked to warn the operator of the sonic pressure hazard; or		N/A
	b) be provided with installation instructions that specify how the installer can ensure that the sound pressure level from equipment at its point of use after installation, will not reach a value, which could cause a hazard. These instructions shall include the measured sound pressure level, and shall identify readily available and practicable protective materials or measures which may be used.		N/A
5.2.4	Equipment with multiple sources of supply		P
	A PCE with connections for multiple energy	Marked with symbol 13 of	P

IEC 62109-1			
Clause	Requirement – Test	Result – Remark	Verdict
	sources shall be marked with symbol 13 of Annex C and the manual shall contain the information required in 5.3.4.	Annex C and explain in user manual.	
	The symbol shall be located on the outside of the unit or shall be prominently visible behind any cover giving access to hazardous parts.	See above.	P
5.2.5	Excessive touch current		P
	Where required by 7.3.6.3.7 the PCE shall be marked with symbol 15 of Annex C. See also 5.3.2 for information to be provided in the installation manual.	Marked with symbol 15 of Table C.1 and relevant information is provided in user's manual.	P
5.3	Documentation		P
5.3.1	General		P
	The documentation provided with the PCE shall provide the information needed for the safe operation, installation, and (where applicable) maintenance of the equipment. The documentation shall include the items required in 5.3.2 through 5.3.4, and the following:	All related informations provided in the user's maunal.	P
	a) explanations of equipment makings, including symbols used		P
	b) location and function of terminals and controls		P
	c) all ratings or specifications that are necessary to safely install and operate the PCE, including the following environmental ratings along with an explanation of their meaning and any resulting installation requirements:		P
	– ENVIRONMENTAL CATEGORY as per 6.1		P
	– WET LOCATIONS classification fort he intended external environment as per 6.1		P
	– POLLUTION DEGREE classification for the intended external environment as per 6.2		P
	– INGRESS PROTECTION rating as per 6.3		P
	– Ambient temperature and relative humidity ratings		P
	– MAXIMUM altitude rating		P
	– OVERVOLTAGE CATEGORY assigned to each input and output port as per 7.3.7.1.2, accompanied by guidance regarding how to ensure that the installation complies with the required overvoltage categories;		P
	d) a warning that when the photovoltaic array is exposed to light, it supplies a d.c. voltage to the		P



IEC 62109-1			
Clause	Requirement – Test	Result – Remark	Verdict
	PCE		
5.3.1.1	Language		P
	Instructions related to safety shall be in a language that is acceptable in the country where the equipment is to be installed.	Instruction related to safety is in English.	P
5.3.1.2	Format		P
	In general, the documentation must be provided in printed form and is to be delivered with the equipment.	The printed form is available and is delivered with the PCE.	P
	For equipment which requires the use of a computer for both installation and operation, documentation may be provided in electronic format without accompanying printed format.	See above.	N/A
5.3.2	Information related to installation		P
	The documentation shall include installation and where applicable, specific commissioning instructions and, if necessary for safety, warnings against hazards which could arise during installation or commissioning of the equipment. The information provided shall include:	All below related informations provided in the user's maunal.	P
	a) assembly, location, and mounting requirements:		P
	b) ratings and means of connection to each source of supply and any requirements related to wiring and external controls, colour coding of leads, disconnection means, or overcurrent protection needed, including instructions that the installation position shall not prevent access to the disconnection means;		P
	c) ratings and means of connection of any outputs from the PCE, and any requirements related to wiring and externals controls, colour coding of leads, or overcurrent protection needed;		P
	d) explanation of the pin-out of connectors for external connections, unless the connector is used for a standard purpose (e.g. RS 232)		P
	e) ventilation requirements;		P
	f) requirements for special services, for example cooling liquid;		N/A
	g) instructions and information relating to sound pressure level if required by 10.2.1;	No hazardous sound level.	P
	h) where required by 14.8.1.3, instructions for the adequate ventilation of the room or location in which PCE containing vented or valve-regulated batteries is located, to prevent the accumulation of hazardous gases;	No battery used in the PCE.	P

IEC 62109-1			
Clause	Requirement – Test	Result – Remark	Verdict
	i) tightening torque to be applied to wiring terminals;		P
	j) values of backfeed short-circuit currents available from the PCE on input and output conductors under fault conditions, if those currents exceed the max. rated current of the circuit, as per 4.4.4.6;	No backfeed current available.	P
	k) for each input to the PCE, the max value of short-circuit current available from the source, for which the PCE is designed; and		P
	l) compatibility with RCD and RCM;	RCMU built in PCE.	P
	m) instructions for protective earthing, including the information required by 7.3.6.3.7 if a second protective earthing conductor is to be installed:		P
	n) where required by 7.3.8, the installation instructions shall include the following or equivalent wording:		P
	“This product can cause a d.c. current in the external protective earthing conductor. Where a residual current-operated protective (RCD) or monitoring (RCM) device is used for protection in a case of direct or indirect contact, only an RCD or RCM of Type B is allowed on the supply side of this product.”		P
	o) for PCE intended to charge batteries, the battery nominal voltage rating, size, and type		P
	p) PV array configuration information, such as ratings, whether the array is to be grounded or floating, any external protection devices needed, etc.		P
5.3.3	Information related to operation		P
	Instructions for use shall include any operating instructions necessary to ensure safe operation, including the following, as applicable:	All related information provided in the user's manual.	P
	– Instructions for adjustment of controls including the effects of adjustment;		P
	– Instructions for interconnection to accessories and other equipment, including indication of suitable accessories, detachable parts and any special materials;		P
	– Warnings regarding the risk of burns from surfaces permitted to exceed the temperature limits of 4.3.2 and required operator actions to reduce the risk; and		P
	– Instructions, that if the equipment is used in a		P

IEC 62109-1			
Clause	Requirement – Test	Result – Remark	Verdict
	manner not specified by the manufacturer, the protection provided by the equipment may be impaired.		
5.3.4	Information related to maintenance		P
	Maintenance instructions shall include the following:	All related information provided in the service maunal.	P
	– Intervals and instructions for any preventive maintenance that is required to maintain safety (for example air filter replacement or periodic re-tightening of terminals);		P
	– Instructions for accessing operator access areas, if any are present, including a warning not to enter other areas of the equipment;		P
	– Part numbers and instructions for obtaining any required operator replaceable parts;		P
	– Instructions for safe cleaning (if recommended)		P
	– Where there is more than one source of supply energizing the PCE, information shall be provided in the manual to indicate which disconnect device or devices are required to be operated in order to completely isolate the equipment.		P
5.3.4.1	Battery maintenance		N/A
	Where required by 14.8.5, the documentation shall include the applicable items from the following list of instructions regarding maintenance of batteries:	No battery inside PCE.	N/A
	– Servicing of batteries should be performed or supervised by personnel knowledgeable about batteries and the required precautions		N/A
	– When replacing batteries, replace with the same type and number of batteries or battery packs		N/A
	– General instructions regarding removal and installation of batteries		N/A
	– CAUTION: Do not dispose of batteries in a fire. The batteries may explode.		N/A
	– CAUTION: Do not open or damage batteries. Released electrolyte is harmful to the skin and eyes. It may be toxic.		N/A
	– CAUTION: A battery can present a risk of electrical shock and high short-circuit current. The following precautions should be observed when working on batteries:		N/A

<b>IEC 62109-1</b>			
Clause	Requirement – Test	Result – Remark	Verdict
	a) Remove watches, rings, or other metal objects.		N/A
	b) Use tools with insulated handles.		N/A
	c) Wear rubber gloves and boots.		N/A
	d) Do not lay tools or metal parts on top of batteries		N/A
	e) Disconnect charging source prior to connecting or disconnecting battery terminals		N/A
	f) Determine if battery is inadvertently grounded. If inadvertently grounded, remove source from ground. Contact with any part of a grounded battery can result in electrical shock. The likelihood of such shock can be reduced if such grounds are removed during installation and maintenance (applicable to equipment and remote battery supplies not having a grounded supply circuit).		N/A
<b>6</b>	<b>ENVIRONMENTAL REQUIREMENTS AND CONDITIONS</b>		P
	The manufacturer shall rate the PCE for the following environmental conditions:		P
	– ENVIRONMENTAL CATEGORY, as in 6.1 below		P
	– Suitability for WET LOCATIONS or not		P
	– POLLUTION DEGREE rating in 6.2 below		P
	– INGRESS PROTECTION (IP) rating, as in 6.3 below		P
	– Ultraviolet (UV) exposure rating, as in 6.4 below		P
	– Ambient temperature and relative humidity ratings, as in 6.5 below		P
6.1	Environmental categories and minimum environmental conditions		P
6.1.1	Outdoor	For outdoor use.	P
6.1.2	Indoor, unconditioned	See above.	N/A
6.1.3	Indoor, conditioned	See above.	N/A
6.2	Pollution degree	PD 2 (inside), PD 3 (outside)	P
6.3	Ingress Protection	IP65.	P
6.4	UV exposure	The shelter is considered necessary for outdoor use. Anti-UV approved AC and DC connectors provided.	P
6.5	Temperature and humidity	Specified by manufacturer.	P
<b>7</b>	<b>PROTECTION AGAINST ELECTRIC SHOCK AND ENERGY HAZARDS</b>		P

IEC 62109-1			
Clause	Requirement – Test	Result – Remark	Verdict
7.1	General	The proper construction of PCE is available for protection against shock and energy hazards during installation, operation and maintenance under normal and single fault conditions.	P
7.2	Fault conditions	See subclause 4.4.	P
7.3	Protection against electric shock		P
7.3.1	General	Each circuit under evaluation is compliance.	P
7.3.2	Decisive voltage classification		P
7.3.2.1	Use of decisive voltage class (DVC)	See below	P
7.3.2.2	Limits of DVC (according table 6)	See subclause 7.3.2.1.	P
7.3.2.3	Short-terms limits of accessible voltages under fault conditions		P
7.3.2.4	Requirements for protection (according table 7)	For circuits evaluation information of PCE, refer to brief description of general product information on previous pages.	P
7.3.2.5	Connection to PELV and SELV circuits	DVC-A is classified for display and communication circuits.	P
7.3.2.6	Working voltage and DVC	See subclause 7.3.2.4.	P
7.3.2.6.1	General	See above.	P
7.3.2.6.2	AC working voltage (see Figure 2)		P
7.3.2.6.3	DC working voltage (see Figure 3)		P
7.3.2.6.4	Pulsating working voltage (see Figure 4)		P
7.3.3	protective separation	For protective separation evaluation information of PCE, refer to brief description of general product information on previous pages.	P
	Protective separation shall be achieved by:		P
	<ul style="list-style-type: none"> <li>▪ double or reinforced insulation, or</li> </ul>		P
	<ul style="list-style-type: none"> <li>▪ protective screening, i.e. by a conductive screen connected to earth by protective bonding in the PCE, or connected to the protective earth conductor itself, whereby the screen is separated from live parts by at least basic insulation, or</li> </ul>		P
	<ul style="list-style-type: none"> <li>▪ protective impedance comprising limitation of current per 7.3.5.3 and of discharged energy</li> </ul>		N/A

IEC 62109-1			
Clause	Requirement – Test	Result – Remark	Verdict
	per 7.3.5.4, or		
	▪ limitation of voltage according to 7.3.5.4.		N/A
	The protective separation shall be fully and effectively maintained under all conditions of intended use of the PCE		P
7.3.4	Protection against direct contact	Protection against electric shock by means of earthed metal enclosure. Any access to touch live parts is impossible.	P
7.3.4.1	General		P
	Protection against direct contact is employed to prevent persons from touching live parts that do not meet the requirements of 7.3.5 and shall be provided by one or more of the measure given in 7.3.4.2 (enclosures and barriers) and 7.3.4.3 (insulation).	See subclause 7.3.2.4.	P
	Open type sub-assemblies and devices do not require protective measures against direct contact but the instruction provided with the equipment must indicate that such measures must be provided in the end equipment or in the installation.		N/A
	Product intended for installation in CLOSED ELECTRICAL OPERATING AREAS, (see 3.9) need not have protective measures against direct contact, except as required by 7.3.4.2.4.		N/A
7.3.4.2	Protection by means of enclosures and barriers	Protection against electric shock by means of earthed metal enclosure.	P
	The following requirements apply where protection against contact with live parts is provided by enclosures or barriers, not by insulation in accordance with 7.3.4.3.		P
7.3.4.2.1	General		P
	Parts of enclosures and barriers that provide protection in accordance with these requirements shall not be removable without the use of a tool (see 7.3.4.2.3).		P
	Polymeric materials used to meet these requirements shall also meet the requirements of 13.6		N/A
7.3.4.2.2	Access probe criteria	Considered.	P
	Protection is considered to be achieved when the separation between the test probes and live parts, when tested as described below, is as follows:		P

IEC 62109-1			
Clause	Requirement – Test	Result – Remark	Verdict
	a) decisive voltage classification A, (DVC A) - the probe may touch the live parts	Considered.	P
	b) decisive voltage classification B, (DVC B) - the probe must not touch bare live parts	No DVC-B in the PCE	N/A
	c) decisive voltage classification C, (DVC C) – the probe must have adequate clearance to live parts, based on the clearance for Basic insulation using the recurring peak working voltage involved,	Considered.	P
7.3.4.2.3	Access probe tests		P
	Compliance with 7.3.4.2.1 is checked by all of the following:		P
	a) Inspection; and	Live parts are enclosed by the earthed metal enclosure and no openings.	P
	b) Tests with the test finger (Figure D.1) and test pin (Figure D.2) of 0E, the results of which shall comply with the requirements of 7.3.4.2.1 a), b), and c) as applicable. Probe tests are performed on openings in the enclosures after removal of parts that can be detached or opened by an operator without the use of a tool, including fuseholders, and with operator access doors and covers open. It is permitted to leave lamps in place for this test. Connectors that can be separated by an operator without use of a tool, shall also be tested during and after disconnection. Any movable parts are to be put in the most unfavourable position.	It is not possible to touch the hazardous live parts by the test finger and test pin.	P
	The test finger and the test pin are applied as above, without appreciable force, in every possible position, except that floor-standing equipment having a mass exceeding 40 kg is not tilted.		P
	Equipment intended for building-in or rack mounting, or for incorporation in larger equipment, is tested with access to the equipment limited according to the method of mounting detailed in the installation instructions.	Not intended for built-in or rack mounting.	N/A
	c) Openings preventing the entry of the jointed test finger ( Figure E-1 of 0E) during test b) above, are further tested by means of straight unjointed test finger (Figure E-3 of 0E), applied with a force of 30 N. If the unjointed finger enters, the test with the jointed finger is repeated except that the finger is applied using any necessary force up to 30 N.	No openings.	N/A
	d) In addition to a) – c) above, top surfaces of	No openings.	N/A

IEC 62109-1			
Clause	Requirement – Test	Result – Remark	Verdict
	enclosure shall be tested with the IP3X probe of IEC 60529. The test probe shall not penetrate the top surface of the enclosure when probed from the vertical direction $\pm 5^\circ$ only.		
7.3.4.2.4	Service access areas	It is not allowed to remove the cover during installation and maintenance when PCE is energized.	P
7.3.4.3	Protection by means of insulation of live parts	See subclause 7.3.2, 7.3.3 and 7.3.4.1.	P
	Where the requirements of 7.3.4.2 are not met, live parts shall be provided with insulation if:		P
	– their working voltage is greater than the maximum limit of decisive voltage class A, or		P
	– for a DVC A or B circuit, protective separation from adjacent circuit of DVC C is not provided (see note “†” under Table 7)		P
7.3.5	Protection in case of direct contact		P
7.3.5.1	General	See below.	P
	Protection in case of direct contact is required to ensure that contact with live parts does not produce a shock hazard.		P
	The protection against direct contact according to 7.3.4 is not required if the circuit contacted is separated from other circuits according to 7.3.2.3, and:		P
	– is of decisive voltage class A and complies with 7.3.5.2, or	Only DCV-A classified circuit can be touched directly, see also 7.3.5.2.	P
	– is provided with protective impedance according to 7.3.5.3, or		N/A
	– is limited in voltage according to 7.3.5.4		N/A
	In addition to the measures as given in 7.3.5.2 to 7.3.5.4, it shall be ensured that in the event of error or polarity reversal of connectors no voltages that exceed DVC A can be connected into a circuit with protective separation. This applies for example to plug-in-sub-assemblies or other plug-in devices which can be plugged-in without the use of a tool (key) or which are accessible without the use of a tool.		P
	Conformity is checked by visual inspection and trial insertion.		P
7.3.5.2	Protection using decisive voltage class A	Comm. port is considered as DVC-A which can be	P



IEC 62109-1			
Clause	Requirement – Test	Result – Remark	Verdict
		accessible and separated from DVC-C by double or reinforced insulation.	
7.3.5.3	Protection by means of protective impedance	This method not considered.	N/A
	Circuits and conductive parts do not require protection against direct contact if any connection to circuits of DVC-B or DVC-C is through protective impedance, and the accessible circuit or part is otherwise provided with protective separation from circuits of DVC-B or DVC-C according 7.3.3.		N/A
7.3.5.3.1	Limitation of current through protective impedance		N/A
	The current available through protective impedance to earth and between simultaneously accessible parts, measured at the accessible live parts, shall not exceed a value of 3,5 mA a.c. or 10 mA d.c. under normal and single-fault conditions.		N/A
7.3.5.3.2	Limitation of discharging energy through protective impedance		N/A
	The discharging energy available between simultaneously accessible parts protected by protective impedance shall not exceed the charging voltage and capacitance limits given in Table 9, which applies to both wet and dry locations, under normal and single fault conditions. Refer to figure 8.		
7.3.5.4	Protection by means of limited voltages	This method not considered.	N/A
	That portion of a circuit that has its voltage reduced to DVC-A by a voltage divider that complies with the following requirements, and that is otherwise provided with protective separation from circuits of DVC-B or DVC-C according to 7.3.3, does not require protection against direct contact.		N/A
	The voltage divider shall be designed so that under normal and single fault conditions, including faults in the voltage division circuit, the voltage across the output of the voltage divider does not exceed the limit for DVC-A.		N/A
	This type of protection shall not be used in case of protective class II or unearthed circuits, because it relies on protective earth being connected.		N/A
7.3.6	Protection against indirect contact		P
7.3.6.1	General		P
	Protection against indirect contact is required to prevent shock- hazardous current being accessible from conductive parts during an insulation failure. This protection shall comply with the requirements for protective class I (basic insulation plus protective earthing), class II (double or reinforced	The PCE is defined as protective class I.	P

IEC 62109-1			
Clause	Requirement – Test	Result – Remark	Verdict
	insulation) or class III (limitation of voltages)		
	That part of a PCE meets the requirements of 7.3.6.2 and 7.3.6.3 is defined as protective class I	The earthing metal enclosure is complied with Protective class I.	P
	That part of a PCE meets the requirements of 7.3.6.4 is defined as protective class II.	The circuit of communication is complied with Protective class II for accessible communication ports.	P
	That part of PCE which meets the requirements of decisive voltage class A and in which no hazardous voltages are derived, is defined as protective class III. No shock hazard is present in such circuits.		N/A
	Where protection against indirect contact is dependent on means provided during installation, the installation instructions shall provide details of the required means and shall indicate the associated hazards.		P
7.3.6.2	Insulation between live parts and accessible conductive parts	See subclaus 7.3.2.3, 7.3.7.4 and 7.3.7.5.	P
	Accessible conductive parts of equipment shall be separated from live parts by insulation meeting the requirements of Table 7 or by clearances as specified in 7.3.7.4 and creepages as specified in 7.3.7.5	The clearances specified in 7.3.7.4 and creepage specified in 7.3.7.5 are complied.	P
7.3.6.3	Protective class I – Protective bonding and earthing		P
7.3.6.3.1	General		P
	Equipment of protective class I shall be provided with protective earthing, and with protective bonding to ensure electrical contact between accessible conductive parts and the means of connection for the external protective earthing conductor, except bonding is not required for:	Suitable protective bonding provided.	P
	a) accessible conductive parts that are protected by one of the measures in 7.3.5.2 to 7.3.5.4, or	DVC-A classified circuit is considered.	P
	b) accessible conductive parts are separated from live parts of DVC-B or -C using double or reinforced insulation.	Display and communication circuits are separated from live parts used double or reinforced insulation.	P
7.3.6.3.2	Requirements for protective bonding	The cross-section of the protective bonding conductor is the same as that for the external protective earthing conductor.	P
	Electrical contact with the means of connection of the external protective earthing conductor shall be achieved by one or more of the following means:		P

IEC 62109-1			
Clause	Requirement – Test	Result – Remark	Verdict
	a) through direct metallic contact;	The connection of external protective earthing conductor is direct metal contact via a terminal with screw.	P
	b) through other conductive parts which are not removed when the PCE or sub-units are used as intended ;		P
	c) through a dedicated protective bonding conductor;	Protective earthing terminal used.	P
	d) through other metallic components of the PCE		N/A
	Where direct metallic contact is used and one or both of the parts involved is painted or coated, the paint or coating shall be removed in the area of contact, or reliably penetrated, to ensure metal to metal contact.		P
	For moving or removable parts, hinges or sliding contacts designed and maintained to have a low resistance are examples of acceptable means if they comply with the requirements of 7.3.6.3.3.		N/A
	Metal ducts of flexible or rigid construction and metallic sheaths shall not be used as protective bonding conductors, unless the device or material has been investigated as suitable for protective bonding purposes.		P
7.3.6.3.3	Rating of protective bonding	See below.	P
	Protective bonding shall withstand the highest thermal and dynamic stresses that can occur to the PCE item(s) concerned when they are subjected to a fault connecting live parts to accessible conductive parts. The protective bonding shall remain effective for as long as a fault to the accessible conductive parts persists or until an upstream protective device removes power from the part.	Suitable protective bonding used.	P
	Protective bonding shall meet following requirements:	See below.	P
	a) For PCE with an overcurrent protective device rating of 16 A or less, the impedance of the protective bonding means shall not exceed 0,1 $\Omega$ during or at the end of the test below.		N/A
	b) For PCE with an overcurrent protective device rating of more than 16 A, the voltage drop in the protective bonding test shall not exceed 2,5 V during or at the end of the test below.	Sub clause 7.3.6.3.5 is considered.	N/A
	As alternative to a) and b) the protective bonding may designed according to the requirements for the external protective earthing conductor in 7.3.6.3.5,	The cross-section of the protective bonding conductor is the same as that for the	P

IEC 62109-1			
Clause	Requirement – Test	Result – Remark	Verdict
	in which case no testing is required.	external protective earthing conductor.	
	The impedance of protective bonding means shall be checked by passing a test current through the bond for a period of time as specified below. The test current is based on the rating of the overcurrent protection for the equipment or part of the equipment under consideration, as follows:		N/A
	a) For pluggable equipment type A, the overcurrent protective device is that provided external to the equipment (for example, in the building wiring, in the mains plug or in an equipment rack);		N/A
	b) For pluggable equipment type B and fixed equipment, the maximum rating of the overcurrent protective device specified in the equipment installation instructions to be provided external to the equipment;		N/A
	c) For a circuit or part of the equipment for which an overcurrent protective device is provided as part of the equipment, the rating of the provided overcurrent device.		N/A
	Voltages are measured from the protective earthing terminal to all parts whose protective bonding means are being considered. The impedance of the protective earthing conductor is not included in the measurement. However, if the protective earthing conductor is supplied with the equipment, it is permitted to include the conductor in the test circuit but the measurement of the voltage drop is made only from the main protective earthing terminal to the accessible part required to be earthed.		N/A
	On equipment where the protective earth connection to a subassembly or to a separate unit is part of a cable that also supplies power to that subassembly or unit, the resistance of the protective bonding conductor in that cable is not included in the protective bond impedance measurements for the subassembly or separate unit, as shown in Figure 11. However, this option is only permitted if the cable is protected by a suitably rated protective device that takes into account the size of the conductor. Otherwise the impedance of the protective bonding conductor between the separate units is to be included, by measuring to the protective earthing terminal where the power source enters the first unit in the system, as shown in Figure 12.		N/A
7.3.6.3.3.1	Test current, duration, and acceptance criteria	The alternative of sub clause 7.3.6.3.5 was considered.	N/A

IEC 62109-1			
Clause	Requirement – Test	Result – Remark	Verdict
	The test current, duration of the test and acceptance criteria are as follows:	(see appended table 7.3.6.3.3)	N/A
	a) For PCE with an overcurrent protective device rating of 16 A or less, the test current is 200% of the overcurrent protective device rating, but not less than 32 A, applied for 120s. The impedance of the protective bonding means during and at the end of the test shall not exceed 0,1 $\Omega$ .		N/A
	b) For PCE with an overcurrent protective device rating of more than 16 A, the test current is 200% of the overcurrent protective device rating and the duration of the test is as shown in Table 10 below. The voltage drop in the protective bonding means, during and at the end of the test, shall not exceed 2,5 V.		N/A
	c) During and after the test, there shall be no melting, loosening, or other damage that would impair the effectiveness of the protective bonding means.		N/A
	The test current is derived from an a.c or d.c supply source, the output of which is not earthed.		N/A
	As an alternative to Table 10, where the time-current characteristic of the overcurrent protective device that limits the fault current in the protective bonding means is known because the device is either provided in the equipment or fully specified in the installation instructions, the test duration may be based on that specific device's time-current characteristic,. The tests are conducted for a duration corresponding to the 200% current value on the time-current characteristic.		N/A
7.3.6.3.4	Protective bonding impedance (routine test)		N/A
	If the continuity of the protective bonding is achieved at any point by a single means only (for example a single conductor or single fastener), or if the PCE is assembled at the installation location, then the impedance of the protective bonding shall also be tested as a routine test. The test shall be as in 7.3.6.3.3, except for the following:	The alternative of sub clause 7.3.6.3.5 was considered.	N/A
	<ul style="list-style-type: none"> <li>▪ the test current may be reduced to any convenient value greater than 10 A sufficient to allow measurement or calculation of the impedance of the protective bonding means:</li> </ul>		N/A
	<ul style="list-style-type: none"> <li>▪ the test duration may be reduced to no less than 2 s</li> </ul>		N/A

IEC 62109-1			
Clause	Requirement – Test	Result – Remark	Verdict
	For equipment subject to the type test in 7.3.6.3.3.1a), the impedance during the routine test shall not exceed 0,1Ω.		N/A
	For equipment subject to the type test in 7.3.6.3.3.1b) the impedance during the routine test shall not exceed 2,5 V divided by the test current required by 7.3.6.3.3.1b).		N/A
7.3.6.3.5	External protective earthing conductor		P
	A protective earthing conductor shall be connected at all times when power is supplied to PCE of protective class I. Unless local wiring regulations state otherwise, the protective earthing conductor cross-sectional area shall be determined from Table 11 or by calculation according to IEC 60364-5-54.	The external protective earthing conductor crosssectional is designed as half of phase conductors with same material. Related statement specified in manual.	P
	If the external protective earthing conductor is routed through a plug and socket or similar means of disconnection, it shall not be possible to disconnect it unless power is simultaneously removed from the part to be protected.		P
	The cross-sectional area of every external protective earthing conductor which does not form part of the supply cable or cable enclosure shall, in any case, be not less than:		P
	<ul style="list-style-type: none"> <li>▪ 2,5 mm<sup>2</sup> if mechanical protection is provided;</li> </ul>		N/A
	<ul style="list-style-type: none"> <li>▪ 4 mm<sup>2</sup> if mechanical protection is not provided.</li> </ul>	Related statement specified in user manual.	P
	For cord-connected equipment, provisions shall be made so that the external protective earthing conductor in the cord shall, in the case of failure of the strain-relief mechanism, be the last conductor to be interrupted.		N/A
7.3.6.3.6	Means of connection for the external protective earthing conductor		P
7.3.6.3.6.1	General		P
	<p>The means of connection for the external protective earthing conductor shall be located near the terminals for the respective live conductors. The means of connections shall be corrosion-resistant and shall be suitable for the connection of cables according to 7.3.6.3.5.</p> <p>The means of connection for the protective earthing conductor shall not be used as a part of the mechanical assembly of the equipment or for other connections.</p> <p>A separate means of connection shall be provided for each external protective earthing conductor.</p>	<p>The external protective earthing terminal block consist of other live conducts as AC connector for connecting PCE to the mains.</p> <p>Corrosion-resistant is considered for connection and bonding points.</p> <p>Separated earthing terminal be provided for protective earthing conductor was</p>	P

IEC 62109-1			
Clause	Requirement – Test	Result – Remark	Verdict
	Connection and bonding points shall be so designed that their current-carrying capacity is not impaired by mechanical, chemical, or electrochemical influences. Where enclosures and/or conductors of aluminium or aluminium alloys are used, particular attention should be given to the problems of electrolytic corrosion.	specified in user manual.	
	The means of connection for the protective earthing conductor shall be permanently marked with:		P
	<ul style="list-style-type: none"> <li>• symbol 7 of Annex C; or</li> </ul>	With the symbol 7 of Table C.1.	P
	<ul style="list-style-type: none"> <li>• the colour coding green-yellow</li> </ul>	The color coding of Green – yellow recommended.	P
	Marking shall not be done on easily changeable parts such as screws.		P
7.3.6.3.7	Touch current in case of failure of the protective earthing conductor		P
	The requirements of this sub-clause shall be satisfied to maintain safety in case of damage to or disconnection of the protective earthing conductor.		P
	For pluggable equipment type A, the touch current measured in accordance with 7.5.4 shall not exceed 3,5 mA a.c. or mA d.c.	(see appended table 7.3.6.3.7)	N/A
	For all other PCE, one or more of the following measure shall be applied, unless the touch current measured in accordance with 7.5.4 using the test network of IEC 60990 test figure 4 shall not exceed 3,5 mA a.c. or 10 mA d.c.	See appended table 7.5.4. In addition, the caution symbol 15 of Table C.1 provided on PCE and in manual.	P
	a) Permanently connected wiring, and:		P
	<ul style="list-style-type: none"> <li>• a cross-section of the protective earthing conductor of at least 10 mm<sup>2</sup> Cu or 16 mm<sup>2</sup> Al; or</li> </ul>		N/A
	<ul style="list-style-type: none"> <li>• automatic disconnection of the supply in case of discontinuity of the protective earthing conductor; or</li> </ul>		P
	<ul style="list-style-type: none"> <li>• provision of an additional terminal for a second protective earthing conductor of the same cross-sectional area as the original protective earthing conductor and installation instruction requiring a second protective earthing conductor to be installed or</li> </ul>		P
	b) Connection with an industrial connector according to IEC 60309 and a minimum protective earthing conductor cross-section of 2,5 mm <sup>2</sup> as part of a multi-conductor power		N/A

IEC 62109-1			
Clause	Requirement – Test	Result – Remark	Verdict
	cable. Adequate strain relief shall be provided.		
	In addition, the caution symbol 15 of Annex C shall be fixed to the product and the installation manual shall provide details of the protective earthing measures required in the installation as required in 5.3.2.		N/A
	When it is intended and allowed to connect two or more PCEs in parallel using one common PE conductor, the above touch current requirements apply to the maximum number of the PCEs to be connected in parallel, unless one of the measures in a)		N/A
	or b) above is used. The maximum number of parallel PCEs is used in the testing and has to be stated in the installation manual.		N/A
7.3.6.4	Protective Class II – Double or Reinforced Insulation	PCE is designed for protective class I.	N/A
	Equipment or parts of equipment designed for protective class II shall have insulation between live parts and accessible surfaces in accordance with 7.3.4.3. The following requirements also apply:		N/A
	<ul style="list-style-type: none"> <li>equipment designed to protective class II shall not have means of connection for the external protective earthing conductor. However this does not apply if the external protective earthing conductor is passed through the equipment to equipment series-connected beyond it. In the latter event, the external protective earthing conductor and its means for connection shall be insulated with basic insulation from the accessible surface of the equipment and from circuits that employ protective separation, extra-low voltage, protective impedance and limited discharging energy, according to 7.3.5. This basic insulation shall correspond to the rated voltage of the series-connected equipment;</li> </ul>		N/A
	<ul style="list-style-type: none"> <li>metal-encased equipment of protective class II may have provision on its enclosure for the connection of an equipotential bonding conductor;</li> </ul>		N/A
	<ul style="list-style-type: none"> <li>equipment of protective class II may have provision for the connection of an earthing conductor for functional reasons or for damping of overvoltages; it shall, however, be insulated as though it is a live part;</li> </ul>		N/A
	<ul style="list-style-type: none"> <li>equipment employing protective class II shall be marked according to 5.1.8.</li> </ul>		N/A



IEC 62109-1			
Clause	Requirement – Test	Result – Remark	Verdict
7.3.7	Insulation Including Clearance and Creepage Distance		P
7.3.7.1	General		P
	This subclause gives minimum requirements for insulation, based on the principles of IEC 60664.		P
	Manufacturing tolerances shall be taken into account during measurement of creepage, clearance, and insulation distance in the PCE.		P
	Insulation shall be selected after consideration of the following influences:		P
	<ul style="list-style-type: none"> <li>• pollution degree</li> </ul>	(see appended table 7.3.7.1.1)	P
	<ul style="list-style-type: none"> <li>• overvoltage category</li> </ul>	(see appended table 7.3.7.1.2)	P
	<ul style="list-style-type: none"> <li>• supply earthing system</li> </ul>	(see appended table 7.3.7.1.3)	P
	<ul style="list-style-type: none"> <li>• insulation voltage</li> </ul>	(see appended table 7.3.7.1.4)	P
	<ul style="list-style-type: none"> <li>• location of insulation</li> </ul>		P
	<ul style="list-style-type: none"> <li>• type of insulation</li> </ul>		P
	Compliance of insulation, creepage distances, and clearance distances, shall be verified by measurement or visual inspection, and the tests of 7.5.		P
7.3.7.1.3	Supply earthing systems	For TN system.	P
	Three basic types of earthing system are described in IEC 60364-1. They are:		P
	<ul style="list-style-type: none"> <li>• TN system: has one point directly earthed, the accessible conductive parts of the installation being connected to that point by protective conductors. Three types of TN systems, TN-C, TN-S and TN-C-S, are defined according to the arrangement of the neutral and protective conductor.</li> </ul>		P
	<ul style="list-style-type: none"> <li>• TT system: has one point directly earthed, the accessible conductive parts of the installation being connected to earth electrodes electrically independent of the earth electrodes of the power system;</li> </ul>		N/A
	<ul style="list-style-type: none"> <li>• IT system: has all live parts isolated from earth or one point connected to earth through an impedance, the accessible conductive parts of the installation being earthed independently or collectively to the earthing system.</li> </ul>		N/A

IEC 62109-1			
Clause	Requirement – Test	Result – Remark	Verdict
7.3.7.1.4	Insulation voltages	PV supply circuits: 6000V (VMAX PV: 1000Vd.c.) AC mains circuits: 4000V (Rated: 3~ 400Va.c.) Other circuits: 2500V (Rated: 230Va.c.)	P
	Table 12 makes use of the circuit system voltage and overvoltage category to define the impulse withstands voltage and the temporary overvoltage.		P
7.3.7.2	Insulation between a circuit and its surroundings		P
7.3.7.2.1	General	Considered.	P
7.3.7.2.2	Circuits connected directly to the mains	Clearances and solid insulation required according to the impulse voltage, temporary overvoltage, or working voltage, whichever gives the most severe requirement.	P
7.3.7.2.3	Circuits other than mains circuits	Clearances and solid insulation required according to the impulse voltage and recurring peak voltage.	P
7.3.7.2.4	Insulation between circuits	Clearances and solid insulation according to the higher impulse voltages. Creepages according of the higher r.m.s. working voltage.	P
7.3.7.3	Functional insulating		P
7.3.7.4	Clearance distances	(see appended table 7.3.7)	P
7.3.7.4.1	Determination	The max. insulation / impulse voltage: 6000V.	P
7.3.7.4.2	Electric field homogeneity	Not considered.	N/A
7.3.7.4.3	Clearance to conductive enclosures	Refer to subclause 7.3.7.4.1 and 13.7.	P
7.3.7.5	Creepage distances	(see appended table 7.3.7)	P
7.3.7.5.1	General		P
7.3.7.5.2	Voltage	The max. voltage: 400Vrms / 1000Vd.c	P
7.3.7.5.3	Materials	Insulating material group IIIb 175 > CTI ≥ 100 assumed.	P
7.3.7.6	Coating	Not used.	N/A
7.3.7.7	PWB spacings for functional insulating	Comply with 7.3.7.4 and 7.3.7.5.	N/A

IEC 62109-1			
Clause	Requirement – Test	Result – Remark	Verdict
7.3.7.8	Solid insulating	(see appended table 7.3.7)	P
7.3.7.8.1	General		P
7.3.7.8.2	Requirements for electrical withstand capability of solid insulation		P
7.3.7.8.2.1	Basic, supplemental, reinforced, and double insulation	Passed the impulse withstand voltage and a.c. or d.c. voltage tests. See appended table 7.5.1, 7.5.2 & 7.5.3. Note: No double or reinforced solid insulation used. No voltage stress on the insulation is greater than 1 kV/mm.	P
7.3.7.8.2.2	Functional insulation	Not used.	N/A
7.3.7.8.3	Thin sheet or tape material	See below.	P
7.3.7.8.3.1	General		P
7.3.7.8.3.2	Material thickness not less than 0,2 mm	Bobbin used in power transformer.	P
7.3.7.8.3.3	Material thickness less than 0,2 mm	Multi-layers mylar sheets provided between primary and secondary in main transformer.	P
7.3.7.8.3.4	Compliance	See subclause 7.3.7.8.3.2.	P
7.3.7.8.4	Printed wiring boards		P
7.3.7.8.4.1	General	Insulation between conductor layers in double-sided singlelayer PWBs meet the requirements of 7.3.7.8.1. Basic, supplementary, double and reinforced insulation meet the appropriate requirements of 7.3.7.8.2.1 or 7.3.7.8.2.2. Functional insulation in PWBs meet the requirements of 7.3.7.8.2.3.	P
7.3.7.8.4.2	Use of coating materials	No coating material used.	N/A
7.3.7.8.5	Wound components	No such wound components.	N/A
7.3.7.8.6	Potting materials	No potting materials used.	N/A
7.3.7.9	Insulation requirements above 30 kHz	Considered.	P
7.3.8	Residual Current-operated protective (RCD) or monitoring (RCM) device compatibility	Built-in RCM unit within the PCE.	N/A
	RCD and RCM are used to provide protection	Under normal and single-fault	N/A

IEC 62109-1			
Clause	Requirement – Test	Result – Remark	Verdict
	against insulation faults in some domestic and industrial installations, additional to that provided by the installed equipment.	conditions, the resulting d.c. component of the current in the protective earthing conductor does not exceed the d.c. current withstand requirements in IEC 60755 and IEC 62020 for RCD and RCM of type B.	
7.3.9	Capacitor discharge	(see appended table 7.3.9)	P
7.3.9.1	Operator access area		N/A
	Equipment shall be so designed that there is no risk of electric shock in operator access areas from charge stored on capacitors after disconnection of the PCE.		N/A
7.3.9.2	Service access areas		P
	Capacitors located behind panels that are removable for servicing, installation, or disconnection shall present no risk of electric shock or energy hazard from charge stored on capacitors after disconnection of the PCE.	The warning symbol 21 of Table C.1 and an indication of the discharge time is placed in a clearly visible position on the protective barrier to avoid unconsciousness contact.	P
7.4	Protection against energy hazards		P
7.4.1	Determination of hazardous energy level	There is no risk of energy hazard in operator access areas, protection of electrical shock by means of earthed metal enclosure.	P
	A hazardous energy level is considered to exist if		P
	a) The voltage is 2 V or more, and power available after 60 s exceeds 240 VA.		P
	b) The stored energy in a capacitor is at a voltage. U of 2 V or more, and the stored energy. E, calculated from the following equation, exceeds 20J:  $E = 0,5 CU^2$		P
7.4.2	Operator Access Areas		P
	Equipment shall be so designed that there is no risk of energy hazard in operator access areas from accessible circuits.	All hazardous energy parts were enclosed within the earthed metal enclosure.	P
7.4.3	Services Access Areas		P
7.5	Electrical tests related to shock hazard	(see appended table 7.5)	P
7.5.1	Impulse voltage test (type test)	See appended table 7.5.1. During the test no puncture, flashover, or sparkover	P

<b>IEC 62109-1</b>			
Clause	Requirement – Test	Result – Remark	Verdict
		occurs.	
7.5.2	Voltage test (dielectric strength test)	See below.	P
7.5.2.1	Purpose of test		P
7.5.2.2	Value and type of test voltage	(see appended table 7.5.2)	P
7.5.2.3	Humidity pre-conditioning	PCE is intended for WET LOCATIONS use.	P
7.5.2.4	Performing the voltage test	Refer to appended table 7.5.2.	P
7.5.2.5	Duration of the a.c. or d.c. voltage test	The full voltage is maintained for 60s.	P
7.5.2.6	Verification of the a.c. or d.c. voltage test	No electrical breakdown occurs during the test.	P
7.5.3	Partial discharge test	No double or reinforced solid insulation used. No voltage stress on the insulation is greater than 1 kV/mm.	N/A
7.5.4	Touch current measurement (type test)		P
	The touch current shall be measured if required by 7.3.6.3.7 and shall not be greater than 3.5 mA a.c. or 10 mA d.c. or special measures of protection as given in 7.3.6.3.7 are required.	(see appended table 7.3.6.3.7)	P
	For type tests on PCE for which wet locations requirements apply according to 6.1, the humidity pre-conditioning of 4.5 shall be performed immediately prior to the touch current test.	See above.	P
7.5.5	Equipment with multiple sources of supply		N/A
<b>8</b>	<b>PROTECTION AGAINST MECHANICAL HAZARDS</b>		P
8.1	General		P
	Operation shall not lead to a mechanical HAZARD in NORMAL CONDITION or SINGLE FAULT CONDITION. Edges, projections, corners, openings, guards, handles and the like, that are accessible to the operator shall be smooth and rounded so as not to cause injury during normal use of the equipment.	Edges, projections, corners, openings, guards, handles and the like, that are accessible to the OPERATOR are smooth and rounded.	P
	Conformity is checked as specified in 8.2 to 8.6.		P
8.2	Moving parts		N/A
	Moving parts shall not be able to crush, cut or pierce parts of the body of an OPERATOR likely to contact them, nor severely pinch the OPERATOR's skin. Hazardous moving parts of equipment, that is moving parts which have the potential to cause injury, shall be so arranged, enclosed or guarded as to provide adequate protection against the risk		N/A

IEC 62109-1			
Clause	Requirement – Test	Result – Remark	Verdict
	of personal injury.		
8.2.1	Protection of service persons		P
	Protection shall be provided such that unintentional contact with hazardous moving parts is unlikely during servicing operations. If a guard over a hazardous moving part may need to be removed for servicing, the marking of symbol 15 of Table D-1 shall be applied on or near the guard.	Barrier and the marking of symbol 15 of Table C.1 is provided for service persons.	P
8.3	Stability		N/A
	Equipment and assemblies of equipment not secured to the building structure before operation shall be physically stable in NORMAL USE.	The PCE is wall mounted equipment.	N/A
8.4	Provisions for lifting and carrying		P
	If carrying handles or grips are fitted to, or supplied with, the equipment, they shall be capable of withstanding a force of four times the weight of the equipment.		P
	Equipment or parts having a mass of 18 kg or more shall be provided with a means for lifting and carrying or directions shall be given in the manufacturer's documentation.		P
8.5	Wall mounting		P
	Mounting brackets on equipment intended to be mounted on a wall or ceiling shall withstand a force of four times the weight of the equipment.	Mounting brackets and wall construction for installation condition are specified in installation manual. Mounting brackets withstand a force of four times the weight of the equipment.	P
8.6	Expelled parts		N/A
	Equipment shall contain or limit the energy of parts that could cause a HAZARD if expelled in the event of a fault.	No such parts.	N/A
<b>9</b>	<b>PROTECTION AGAINST FIRE HAZARDS</b>		P
9.1	Resistance to fire		P
	This subclause specifies requirements intended to reduce the risk of ignition and the spread of flame, both within the equipment and to the outside, by the appropriate use of materials and components and by suitable construction.	Suitable and appropriate materials, components and construction are used to reduce the risk of ignition and the spread of flame.	P
9.1.1	Reducing the risk of ignition and spread of flame		P
	For equipment or a portion of equipment, there are two alternative methods of providing protection against ignition and spread of flame that could		P

IEC 62109-1			
Clause	Requirement – Test	Result – Remark	Verdict
	affect materials, wiring, wound components and electronic components such as integrated circuits, transistors, thyristors, diodes, resistors and capacitors.		
9.1.2	Conditions for a fire enclosure		P
	A FIRE ENCLOSURE is required for equipment or parts of equipment for which Method 2 is not fully applied and complied with.	A FIRE ENCLOSURE is required for equipment or parts of equipment.	P
9.1.2.1	Parts requiring a fire enclosure		P
	Except where Method 2 is used, or as permitted in 9.1.2.2, the following are considered to have a risk of ignition and, therefore, require a FIRE ENCLOSURE:		P
	– components in PRIMARY CIRCUITS		P
	– components in SECONDARY CIRCUITS supplied by power sources which exceed the limits for a LIMITED POWER SOURCE as specified in 9.2;		P
	– components in SECONDARY CIRCUITS supplied by a LIMITED POWER SOURCE as specified in 9.2, but not mounted on a material of FLAMMABILITY CLASS V-1;		P
	– components within a power supply unit or assembly having a limited power output complying with the criteria for a LIMITED POWER SOURCE as specified in 9.2, including overcurrent protective devices, limiting impedances, regulating networks and wiring, up to the point where the LIMITED POWER SOURCE output criteria are met;		P
	– components having unenclosed arcing parts, such as open switch and relay contacts and commutators, in a circuit at HAZARDOUS VOLTAGE or at a HAZARDOUS ENERGY LEVEL; and		P
	– insulated wiring, except as permitted in 9.1.2.2.		P
9.1.2.2	Parts not requiring a fire enclosure	See above.	N/A
9.1.3	Materials requirements for protection against fire hazard		P
9.1.3.1	General		P
	ENCLOSURES, components and other parts shall be so constructed, or shall make use of such materials, that the propagation of fire is limited.	Metal enclosure provided.	P
9.1.3.2	Materials for fire enclosures		P

<b>IEC 62109-1</b>			
Clause	Requirement – Test	Result – Remark	Verdict
	If an enclosure material is not classified as specified below, a test may be performed on the final enclosure or part of the enclosure, in which case the material shall additionally be subjected to periodic SAMPLE testing.	Metal enclosure provided.	P
9.1.3.3	Materials for components and other parts outside fire enclosures		P
	Except as otherwise noted below, materials for components and other parts (including MECHANICAL ENCLOSURES, ELECTRICAL ENCLOSURES and DECORATIVE PARTS); located outside FIRE ENCLOSURES, shall be of FLAMMABILITY CLASS HB.	FLAMMABILITY CLASS HB or better used.	P
9.1.3.4	Materials for components and other parts inside fire enclosures	FLAMMABILITY CLASS V- 2 or better used.	P
9.1.3.5	Materials for air filter assemblies	No such materials.	N/A
9.1.4	Openings in fire enclosures		P
9.1.4.1	General	No openings in fire enclosures.	P
	For equipment that is intended to be used or installed in more than one orientation as specified in the product documentation, the following requirements apply in each orientation.		P
	These requirements are in addition to those in the following sections:		P
	– 7.3.4, Protection against direct contact;		P
	– 7.4, Protection against energy hazards;		P
	– 13.5, Openings in enclosures		P
9.1.4.2	Side openings treated as bottom openings	See above.	N/A
9.1.4.3	Openings in the bottom of a fire enclosure	See above.	N/A
	The bottom of a FIRE ENCLOSURE or individual barriers, shall provide protection against emission of flaming or molten material under all internal parts, including partially enclosed components or assemblies, for which Method 2 of 9.1.1 has not been fully applied and complied with.		N/A
9.1.4.4	Equipment for use in a CLOSED ELECTRICAL OPERATING AREA		N/A
	The requirements of 9.1.4.3 do not apply to FIXED EQUIPMENT intended only for use in a CLOSED ELECTRICAL OPERATING AREA and to be mounted on a concrete floor or other non-combustible surface. Such equipment shall be marked as follows:		N/A



<b>IEC 62109-1</b>			
Clause	Requirement – Test	Result – Remark	Verdict
	WARNING: FIRE HAZARD SUITABLE FOR MOUNTING ON CONCRETE OR OTHER NON-COMBUSTIBLE SURFACE ONLY		N/A
9.1.4.5	Doors or covers in fire enclosures		P
9.1.4.6	Additional requirements for openings in transportable equipment	PCE not for transportable equipment.	N/A
9.2	LIMITED POWER SOURCES	Not applied.	N/A
9.2.1	General		N/A
9.2.2	Limited power source tests	(see appended table 9.2)	N/A
9.3	Short-circuit and overcurrent protection		P
9.3.1	General		P
	The PCE shall not present a hazard, under short-circuit or overcurrent conditions at any port, including phase-to-phase, phase-to-earth and phase-to-neutral, and adequate information shall be provided to allow proper selection of external wiring and external protective devices.	No overcurrent hazards was presented by short circuits and overloads tests. Refer to sub-clause 4.4.4.	P
9.3.2	Protection against short-circuits and overcurrents shall be provided for all input circuits, and for output circuits that do not comply with the requirements for limited power sources in 9.2, except for circuits in which no overcurrent hazard is presented by short-circuits and overloads.		P
9.3.3	Protective devices provided or specified shall have adequate breaking capacity to interrupt the maximum short circuit current specified for the port to which they are connected. If protection that is provided integral to the PCE for an input port is not rated for the short-circuit current of the circuit in which it is used, the installation instructions shall specify that an upstream protective device, rated for the prospective short-circuit current of that port, shall be used to provide backup protection.	Upstream protective device for backup protection is specified in the installation manual.	P
<b>10</b>	<b>PROTECTION AGAINST SONIC PRESSURE HAZARDS</b>		P
10.1	General		P
	The equipment shall provide protection against the effect of sonic pressure. Conformity tests are carried out if the equipment is likely to cause such HAZARDS.		P
10.2	Sonic pressure and Sound level		P
10.2.1	Hazardous Noise Levels	Sound pressure level is lower than 80dB.	P
<b>11</b>	<b>PROTECTION AGAINST LIQUID HAZARDS</b>		N/A
11.1	Liquid Containment, Pressure and Leakage	No liquid contained in this	N/A

IEC 62109-1			
Clause	Requirement – Test	Result – Remark	Verdict
		system, and energy storage battery used.	
	The liquid containment system components shall be compatible with the liquid to be used.		N/A
	There shall be no leakage of liquid onto live parts as a result of:		N/A
	a) Normal operation, including condensation;		N/A
	b) Servicing of the equipment; or		N/A
	c) Inadvertent loosening or detachment of hoses or other cooling system parts over time.		N/A
11.2	Fluid pressure and leakage		N/A
11.2.1	Maximum pressure		N/A
11.2.2	Leakage from parts		N/A
11.2.3	Overpressure safety device		N/A
11.3	Oil and grease		N/A
<b>12</b>	<b>CHEMICAL HAZARDS</b>		N/A
12.1	General	No chemical Hazards.	N/A
<b>13</b>	<b>PHYSICAL REQUIREMENTS</b>		P
13.1	Handles and manual controls	It shall not be possible to fix them in wrong position if this might result in a hazard.	P
	Handles, knobs, grips, levers and the like shall be reliably fixed so that they will not work loose in normal use, if this might result in a hazard. Sealing compounds and the like, other than self-hardening resins, shall not be used to prevent loosening. If handles, knobs and the like are used to indicate the position of switches or similar components, it shall not be possible to fix them in a wrong position if this might result in hazard.		P
13.1.1	Adjustable controls	No such controls.	N/A
13.2	Securing of parts	Screws, nuts, washers, springs or similar parts are secured so as to withstand mechanical stresses occurring	P
13.3	Provisions for external connections		P
13.3.1	General	Appropriate provisions for external connections applied.	P
13.3.2	Connection to an a.c. Mains supply		P
13.3.2.1	General	Terminals provided for permanent connection to the PV supply.	P

IEC 62109-1			
Clause	Requirement – Test	Result – Remark	Verdict
	For safe and reliable connection to a MAINS supply, equipment shall be provided with one of the following:		P
	– terminals or leads or a non-detachable power supply cord for permanent connection to the supply; or		P
	– a non-detachable power supply cord for connection to the supply by means of a plug		N/A
	– an appliance inlet for connection of a detachable power supply cord; or		N/A
	– a mains plug that is part of direct plug-in equipment as in 13.3.8		N/A
13.3.2.2	Permanently connected equipment	A set of terminals as specified in 13.3.3 for external connection of supply cords.	P
13.3.2.3	Appliance inlets		N/A
13.3.2.4	Power supply cord	Not provided, but technical requirements provided in user manual.	N/A
13.3.2.5	Cord anchorages and strain relief	No power supply cords provided.	N/A
	For equipment with a non-detachable power supply cord, a cord anchorage shall be supplied such that:		N/A
	– the connecting points of the cord conductors are relieved from strain; and		N/A
	– the outer covering of the cord is protected from abrasion.		N/A
13.3.2.6	Protection against mechanical damage	No power supply cords provided, however plastic inlet bushings provided ready for use.	N/A
13.3.3	Wiring terminals for connection of external conductors		P
13.3.3.1	Wiring terminals	Terminals for power supply cords connection by means of screws.	P
13.3.3.2	Screw terminals	Screws and nuts which clamp external supply conductors have a thread conforming to ISO 261 or ISO 262.	P
13.3.3.3	Wiring terminal sizes	The terminals meet the temperature rise test of 4.3 when connected using wire sizes as specified in the	P

IEC 62109-1			
Clause	Requirement – Test	Result – Remark	Verdict
		documentation or in Table 24.	
13.3.3.4	Wiring terminal design	Lug terminals applied, and the cable lug clamped by nut.	P
13.3.3.5	Grouping of wiring terminals	Terminals located in proximity to each other.	P
13.3.3.6	Stranded wire	Lug terminals applied.	P
13.3.4	Supply wiring space	Lug terminals applied, and the cable lug is clamped by nut without the risk of damage to the conductors or their insulation.	P
13.3.5	Wire bending space for wires 10 mm <sup>2</sup> and greater	Considered.	P
13.3.6	Disconnection from supply sources	Disconnect devices provided.	P
13.3.7	Connectors, plugs and sockets	The misconnection is unlikely for PV or DC connectors.	P
13.3.8	Direct plug-in equipment	Not direct plug-in use.	N/A
13.4	Internal wiring and connections		P
13.4.1	General	The insulation, conductors and routing of all wires of the equipment is suitable for the electrical, mechanical, thermal and environmental conditions of use.	P
13.4.2	Routing	Wires are routed away from sharp edges, screw threads, burrs, fins, moving parts, drawers, and similar parts, which could abrade the wire insulation.	P
13.4.3	Colour coding	The green/yellow color coding wire only used for protective earthing conductor.	P
13.4.4	Splices and connections	All splices and connections are mechanically adequate secure and provided electrical continuity. The likelihood of loose is impossible.	P
13.4.5	Interconnections between parts of the PCE	The communication cable only used for servicing, no any physical damage or mechanical damage likely.	P
13.5	Openings in enclosures		N/A
13.5.1	Top and side openings		N/A

<b>IEC 62109-1</b>			
Clause	Requirement – Test	Result – Remark	Verdict
	Openings in the top and sides of ENCLOSURES shall be so located or constructed that it is unlikely that objects will enter the openings and create hazards by contacting bare conductive parts.		N/A
13.6	Polymeric Materials		P
13.6.1	General	See below.	P
13.6.1.1	Thermal index or capability	Appropriate electrical, mechanical, thermal and flammability degree polymeric materials provided.	P
13.6.2	Polymers serving as enclosures or barriers preventing access to hazards	Metal enclosure used.	N/A
13.6.2.1	Stress relief test	See above.	N/A
13.6.3	Polymers serving as solid insulation	See below.	P
13.6.3.1	Resistance to arcing		P
13.6.4	UV resistance	Metal enclosure provided.	N/A
	Polymeric parts of an OUTDOOR ENCLOSURE required for compliance with this standard shall be sufficiently resistance to degradation by ultra-violet (UV) radiation		N/A
13.7	Mechanical resistance to deflection, impact, or drop		P
13.7.1	General	See below.	P
13.7.2	250-N deflection test for metal enclosures	A steady force of 250 N applied for 5 s, after test no hazards occurred.	P
13.7.3	7-J impact test for polymeric enclosures	Impact test applied on the display screen cover.	P
13.7.4	Drop test	Not for hand - held, direct plug - in, or transportable equipment.	N/A
13.8	Thickness requirements for metal enclosures		P
13.8.1	General		P
13.8.2	Cast metal		N/A
13.8.3	Sheet metal		N/A
<b>14</b>	<b>COMPONENTS</b>		P
14.1	General	(see appended table 14)	P
	Where safety is involved, components shall be used in accordance with their specified RATINGS unless a specific exception is made. They shall conform to one of the following:		P

IEC 62109-1			
Clause	Requirement – Test	Result – Remark	Verdict
	a) applicable safety requirements of a relevant IEC standard. Conformity with other requirements of the component standard is not required. If necessary for the application, components shall be subjected to the test of this standard, except that it is not necessary to carry out identical or equivalent tests already performed to check conformity with the component standard;		P
	b) the requirements of this standard and, where necessary for the application, any additional applicable safety requirements of the relevant IEC component standard;		P
	c) if there is no relevant IEC standard, the requirements of this standard;		P
	d) applicable safety requirements of a non-IEC standard which are at least as high as those of the applicable IEC standard, provided that the component has been approved to the non-IEC standard by a recognized testing authority.		P
	Components such as optocouplers, capacitors, transformers, and relays connected across basic, supplemental, reinforced, or double insulation shall comply with the requirements applicable for the grade of insulation being bridged, and if not previously certified to the applicable component safety standard shall be subjected to the voltage test of 7.5.2 as routine test.		P
14.2	Motor Over temperature Protection		N/A
	Motors which, when stopped or prevented from starting (see 4.4.4.3), would present an electric shock HAZARD, a temperature HAZARD, or a fire HAZARD, shall be protected by an over temperature or thermal protection device meeting the requirements of 14.3.		N/A
14.3	Over temperature protection devices	Approved overtemperature protective devices used and for which appropriate rating was selected for use and do not operate in normal use. For overtemperature protection test or evaluation see appended table 4.4.4.	P
14.4	Fuse holders	Fuse holders with fuses are not intended to be replaceable by an OPERATOR.	N/A
14.5	MAINS voltage selecting devices	No such devices.	N/A

IEC 62109-1			
Clause	Requirement – Test	Result – Remark	Verdict
14.6	Printed circuit boards		P
	Printed circuit boards shall be made of material with a flammability classification of V-1 of IEC 60707 or better.	PCB materials with a flammability classification of V-1 or better used.	P
	This requirement does not apply to thin-film flexible printed circuit boards that contain only circuits powered from limited power sources meeting the requirements of 9.2.		P
	Conformity of the flammability RATING is checked by inspection of data on the materials. Alternatively, conformity is checked by performing the V-1 tests specified in IEC 60707 on three samples of the relevant parts.		P
14.7	Circuits or components used as transient overvoltage limiting devices		N/A
	If control of transient overvoltage is employed in the equipment, any overvoltage limiting component or circuit shall be tested with the applicable impulse withstand voltage of Table 7-10 using the test method from 7.5.1 except 10 positive and 10 negative impulses are to be applied and may be spaced up to 1 min apart.	No such components.	N/A
14.8	Batteries		N/A
	Equipment containing batteries shall be designed to reduce the risk of fire, explosion and chemical leaks under normal conditions and after a single fault in the equipment including a fault in circuitry within the equipment battery pack.		N/A
14.8.1	Battery Enclosure Ventilation		N/A
14.8.1.1	Ventilation requirements		N/A
14.8.1.2	Ventilation testing		N/A
14.8.1.3	Ventilation instructions		N/A
14.8.2	Battery Mounting		N/A
	Compliance is verified by the application of the force to the battery's mounting surface. The test force is to be increased gradually so as to reach the required value in 5 to 10 s, and is to be maintained at that value for 1 min. A non-metallic rack or tray shall be tested at the highest normal condition operating temperature.		N/A
14.8.3	Electrolyte spillage		N/A
	Battery trays and cabinets shall have an electrolyte-resistant coating.		N/A
	The ENCLOSURE or compartment housing a VENTED BATTERY shall be constructed so that		N/A

IEC 62109-1			
Clause	Requirement – Test	Result – Remark	Verdict
	spillage or leakage of the electrolyte from one battery will be contained within the ENCLOSURE and be prevented from:		
	a) reaching the PCE outer surfaces that can be contacted by the USER		N/A
	b) contaminating adjacent electrical components or materials; and		N/A
	c) bridging required electrical distances		N/A
14.8.4	Battery Connections		N/A
	Reverse battery connection of the terminals shall be prevented if reverse connection could result in a hazard within the meaning of this Standard		N/A
14.8.5	Battery maintenance instructions		N/A
	The information and instructions listed in 5.3.4.1 shall be included in the operator manual for equipment in which battery maintenance is performed by the operator, or in the service manual if battery maintenance is to be performed by service personnel only.		N/A
14.8.6	Battery accessibility and maintainability		N/A
	Battery terminals and connectors shall be accessible for maintenance with the correct TOOLS. Batteries with liquid electrolyte, requiring maintained shall be so located that the battery cell caps are accessible for electrolyte tests and readjusting of electrolyte levels.		N/A
15	Software and firmware performing safety functions	Single fault safe compliance. Failures evaluation and risk analysis were performed by means of fault simulation or single fault conditions. (refer to subclause of 4.4.4).	P



IEC 62109-1			
Clause	Requirement – Test	Result – Remark	Verdict

4.2.2.6/4.7 TABLE: : electrical data in normal condition							P
Type	U (V) DC	I (A) DC	P (kW) DC	U (V) grid	I (A) AC	P (kW) AC	
Model :HYD 10KTL-3PH							
Inverter (PV input)	220.3	48.992	10.795	230.7	14.85	10.27	
	600.9	17.682	10.626	230.7	14.95	10.34	
	849.1	12.772	10.845	229.5	15.33	10.54	
Inverter (Battery input)	203.3	53.393	10.854	230.5	14.79	10.22	
	804.3	13.030	10.483	230.6	14.72	10.16	
Off-grid (PV input)	217.1	47.724	10.360	230.8	14.50	10.04	
	597.0	17.360	10.364	230.8	14.50	10.04	
	852.0	12.112	10.319	231.1	14.52	10.07	
Off-grid (Battery input)	200.3	54.110	10.837	230.2	15.08	10.37	
	804.9	13.764	11.076	231.1	15.48	10.74	
Charger	198.0	48.382	9.584	230.3	14.65	10.11	
	799.9	12.224	9.782	230.4	14.63	10.10	
Model :HYD 15KTL-3PH							
Inverter (PV input)	353.8	44.983	15.914	231.1	22.08	15.30	
	598.0	26.285	15.719	230.1	22.17	15.29	
	850.2	18.518	15.743	230.0	22.17	15.29	
Inverter (Battery input)	301.1	52.251	15.736	230.8	21.79	15.08	
	796.0	19.507	15.531	230.8	21.79	15.06	
Off-grid (PV input)	350.8	44.382	15.568	230.7	21.69	15.01	
	595.7	25.942	15.453	230.8	21.81	15.10	
	848.2	15.260	15.487	231.1	21.72	15.06	
Off-grid (Battery input)	299.3	54.420	16.287	230.3	22.82	15.74	
	802.4	20.505	16.452	231.0	23.01	15.94	
Charger	299.3	48.572	14.540	229.9	22.02	15.18	
	803.4	18.156	14.590	229.1	21.96	15.05	
Model :HYD 20KTL-3PH							

IEC 62109-1						
Clause	Requirement – Test			Result – Remark		Verdict
Inverter (PV input)	452.4	46.658	21.105	230.4	29.49	20.37
	603.5	34.791	20.995	230.3	29.52	20.39
	852.4	24.679	21.036	230.4	29.53	20.39
Inverter (Battery input)	399.0	52.762	21.051	230.3	29.24	20.19
	801.9	26.111	20.938	230.3	29.36	20.26
Off-grid (PV input)	449.6	46.259	20.798	230.5	29.04	20.08
	596.3	34.732	20.711	230.5	29.09	20.12
	849.8	24.443	20.771	230.6	29.32	20.29
Off-grid (Battery input)	403.1	54.383	21.924	230.6	30.18	20.88
	803.5	26.862	21.583	230.7	30.19	20.89
Charger	402.5	47.599	19.156	230.5	28.86	19.95
	804.5	24.237	19.505	228.8	29.42	20.15
Supplementary information:						

IEC 62109-1					
Clause	Requirement – Test	Result – Remark			Verdict
<b>4.3</b>	<b>TABLE: Heating Test</b>				<b>P</b>
	test voltage (V) .....	See below			—
	t1 (°C).....	See below			—
	t2 (°C) .....	See below			—
Thermocouple Locations		Max. temperature measured (°C)			Limit, (°C)
Conditions:		Inverter model(PV input)			--
Supplied Voltage [Vd.c.]	450	450	850	850	--
Ambient [°C]	45	60	45	60	--
PV1 input wire	67.3	82.3	63.6	74.9	105
BAT2 input wire	59.0	74.2	57.5	69.7	105
PV input connector	61.4	76.5	59.9	71.3	85
Display buttons	50.4	65.8	50.5	64.3	85
PV terminal	47.4	63.2	46.2	61.1	85
EUT front	54.3	69.8	54.9	68.0	70
EUT side	50.4	66.0	49.8	63.1	70
MOS tube Q7	65.9	82.2	61.8	74.2	130
Fan	71.5	72.9	71.8	72.3	--
Inverter coil R	97.4	102.4	102.4	103.3	110
Inverter coil S	100.4	105.4	105.4	104.8	110
Inverter coil T	91.3	96.3	96.3	98.8	110
PV1 inductor coil	54.7	95.3	59.7	71.0	110
PV2 inductor coil	55.8	99.2	60.8	72.2	110
Battery2 inductor coil	46.9	67.2	51.9	62.7	110
Battery1 inductor coil	45.8	64.4	50.8	61.3	110
Power board					
MOV3	59.7	74.9	58.3	70.4	--
Capacitance C67	72.4	88.0	64.8	76.6	105
Capacitance C35	70.4	86.2	68.3	78.9	105
Inductor L4	72.6	87.5	65.5	77.0	110
Y capacitance C38	64.9	80.2	62.0	73.8	100
MOV6	62.7	77.9	60.2	72.1	100
BUS capacitance	66.8	82.0	68.0	76.8	105

IEC 62109-1					
Clause	Requirement – Test			Result – Remark	Verdict
Capacitance C93	72.1	87.8	72.9	81.7	105
MOS tube Q3	50.7	66.9	48.1	63.0	130
MOS tube Q4	50.3	66.4	48.1	62.9	130
MOS tube Q8	53.1	68.9	50.4	64.5	130
MOS tube Q9	49.2	65.2	47.1	61.9	130
MOS tube Q5	56.7	72.9	51.6	66.1	130
MOS tube Q6	53.1	69.1	49.5	64.0	130
MOS tube Q11	55.8	71.9	50.0	64.5	130
MOS tube Q10	52.3	68.3	48.6	63.3	130
Diode D7	74.9	90.3	63.5	76.8	130
Diode D8	68.5	84.0	58.1	72.3	130
MOS tube Q17	73.8	91.2	51.5	65.7	130
MOS tube Q18	83.3	101.3	54.3	68.1	130
Diode D10	78.1	94.1	70.1	81.8	130
Diode D9	76.4	92.0	65.4	78.3	130
MOS tube Q19	86.0	104.3	61.4	73.6	130
MOS tube Q20	80.4	99.4	56.3	69.7	130
INV IGBT	88.1	103.5	90.5	93.9	130
Output board					
Capacitance C20	63.9	79.3	75.9	64.8	105
Capacitance ECB1	71.0	86.3	82.1	74.2	105
Capacitance CY10	60.8	76.1	72.8	61.5	110
Capacitance C60	61.6	77.0	73.5	62.1	105
Common mode inductor L1	71.6	86.9	82.5	75.6	110
Differential mode inductor L3	93.9	106.4	103.6	101.3	110
Common mode inductor L2	67.5	82.4	77.6	68.2	110
Capacitance C30	69.0	84.1	79.4	69.9	105
Capacitance C82	63.2	78.5	75.0	63.8	105
Lightning protector SPD2	61.5	76.8	73.2	61.9	100
Heat sink	47.9	61.1	59.8	45.5	70
Switch	46.9	62.6	60.7	46.2	70
Outout wire	62.2	77.4	73.6	62.3	105
Output terminal	52.3	68.1	65.5	51.7	85
Transformer T3	68.7	83.7	80.1	71.4	110

IEC 62109-1						
Clause	Requirement – Test			Result – Remark		Verdict
Transformer T1	73.3	87.8	85.4	76.3	110	
Thermocouple Locations						
Max. temperature measured (°C)					Limit, (°C)	
Conditions:	Inverter model (Battery input)		Charger model		--	
Supplied Voltage [Vd.c.]	600	600	230Vac	230 Vac	--	
Ambient [°C]	45	60	45	60	--	
PV1 input wire	62.7	61.2	62.4	77.9	105	
BAT2 input wire	62.5	78.3	60.5	76.1	105	
PV input connector	58.5	78.2	58.6	74.0	85	
Display buttons	49.4	73.8	48.7	63.8	85	
PV terminal	47.8	64.5	47.2	62.4	85	
EUT front	53.3	62.8	52.3	67.5	70	
EUT side	50.5	68.6	50.3	65.8	70	
MOS tube Q7	59.5	66.0	60.8	76.9	130	
Fan	69.4	75.6	69.0	72.0	--	
Inverter coil R	95.7	72.3	97.1	103.3	110	
Inverter coil S	97.5	106.3	97.6	104.8	110	
Inverter coil T	89.4	107.8	88.4	105.2	110	
PV1 inductor coil	51.2	107.4	50.9	66.0	110	
PV2 inductor coil	50.8	66.6	50.7	65.9	110	
Battery2 inductor coil	62.6	66.2	59.5	75.5	110	
Battery1 inductor coil	61.4	78.7	58.7	74.7	110	
Power board						
MOV3	64.2	79.9	62.9	78.5	--	
Capacitance C67	64.7	81.1	64.4	80.2	105	
Capacitance C35	64.3	80.2	64.6	80.0	105	
Inductor L4	64.6	80.5	64.0	79.3	110	
Y capacitance C38	63.8	79.5	63.1	78.5	100	
MOV6	61.8	77.4	61.6	76.8	100	
BUS capacitance	63.5	78.8	63.2	78.0	105	
Capacitance C93	66.4	82.5	67.4	83.1	105	
MOS tube Q3	81.7	98.8	85.0	105.0	130	
MOS tube Q4	73.2	90.0	92.9	114.0	130	

IEC 62109-1					
Clause	Requirement – Test		Result – Remark		Verdict
MOS tube Q8	85.3	105.0	80.4	107.5	130
MOS tube Q9	77.2	95.9	60.0	77.4	130
MOS tube Q5	77.4	94.0	82.3	101.9	130
MOS tube Q6	74.5	91.1	92.9	113.6	130
MOS tube Q11	79.5	98.0	57.4	74.6	130
MOS tube Q10	78.9	97.5	60.6	78.6	130
Diode D7	58.5	74.6	58.6	75.2	130
Diode D8	83.2	75.2	58.3	75.3	130
MOS tube Q17	57.6	73.8	55.2	72.0	130
MOS tube Q18	56.3	72.3	55.5	72.0	130
Diode D10	61.0	77.1	62.9	79.3	130
Diode D9	58.9	75.0	59.4	76.0	130
MOS tube Q19	58.8	74.7	59.4	75.6	130
MOS tube Q20	56.3	72.3	56.3	72.6	130
INV IGBT	77.4	93.9	77.1	94.1	130
Output board					
Capacitance C20	61.7	77.3	61.3	76.4	105
Capacitance ECB1	65.6	81.1	68.2	82.9	105
Capacitance CY10	58.9	74.2	58.5	73.7	110
Capacitance C60	59.5	74.9	59.2	74.5	105
Common mode inductor L1	66.5	82.3	67.6	83.3	110
Differential mode inductor L3	80.6	96.8	86.3	101.8	110
Common mode inductor L2	64.0	79.6	63.3	78.9	110
Capacitance C30	65.1	80.9	65.2	80.4	105
Capacitance C82	60.7	76.3	60.8	75.8	105
Lightning protector SPD2	59.2	74.7	59.2	74.1	100
Heat sink	58.5	74.5	47.4	63.0	70
Switch	47.0	62.2	46.6	61.7	70
Outout wire	60.0	75.5	59.5	74.7	105
Output terminal	51.1	66.6	50.3	65.6	85
Transformer T3	66.7	82.0	66.4	81.1	110
Transformer T1	72.0	86.6	71.5	85.5	110
Supplementary information:					
	<b>TABLE: Heating test, resistance method</b>				--

IEC 62109-1					
Clause	Requirement – Test			Result – Remark	Verdict
	Test voltage (V)..... :			--	—
	Ambient, t <sub>1</sub> (°C)..... :			--	—
	Ambient, t <sub>2</sub> (°C)..... :			--	—
Temperature rise of winding	R <sub>1</sub> (Ω)	R <sub>2</sub> (Ω)	ΔT (K)	Max. dT (K)	Insulation class
--	--	--	--	--	--
Supplementary information:					

IEC 62109-1			
Clause	Requirement – Test	Result – Remark	Verdict

4.4		TABLE: fault condition tests						P
		ambient temperature (°C) .....: 25°C, if not stated otherwise					—	
No.	component No.	fault	test voltage (V)	test time	fuse No.	fuse current (A)	result	
1	Relay defect RL1 pin4-pin3	Short before start up	PV: 600Vdc Battery side: 600Vdc AC output: 230Vac	10min.	--	--	Indicate Relay fault,error code“ID41”(RelayFail).Do not connect to AC mainsn.No damage,no hazards.	
2	Relay defect RL2 pin4-pin3	Short before start up	PV: 600Vdc Battery side: 600Vdc AC output: 230Vac	10min.	--	--	Indicate Relay fault,error code“ID41”(RelayFail).Do not connect to AC mainsn.No damage,no hazards.	
3	Relay defect RL3 pin4-pin3	Short before start up	PV: 600Vdc Battery side: 600Vdc AC output: 230Vac	10min.	--	--	Indicate Relay fault,error code“ID41”(RelayFail).Do not connect to AC mainsn.No damage,no hazards.	
4	Relay defect RL4 pin4-pin3	Short before start up	PV: 600Vdc Battery side: 600Vdc AC output: 230Vac	10min.	--	--	Indicate Relay fault,error code“ID41”(RelayFail).Do not connect to AC mainsn.No damage,no hazards.	
5	Relay defect RL5 pin4-pin3	Short before start up	PV: 600Vdc Battery side: 600Vdc AC output: 230Vac	10min.	--	--	Indicate Relay fault,error code“ID41”(RelayFail).Do not connect to AC mainsn.No damage,no hazards.	
6	Relay defect RL6 pin4-pin3	Short before start up	PV: 600Vdc Battery side: 600Vdc AC output: 230Vac	10min.	--	--	Indicate Relay fault,error code“ID41”(RelayFail).Do not connect to AC mainsn.No damage,no hazards.	
7	Grid voltage monitoring R137	Open	PV: 600Vdc Battery side: 600Vdc AC output: 230Vac	10min.	--	--	Output a.c. relays operated, disconnected with grid. error code“ID02”(GridUVP).Do not connect to AC mainsn.No damage,no hazards.	
8	Grid voltage monitoring R 140	Short	PV: 600Vdc Battery side: 600Vdc AC output: 230Vac	10min.	--	--	Output a.c. relays operated, disconnected with grid. error code“ID01”(GridOVP).Do not connect to AC mainsn.No damage,no hazards.	



IEC 62109-1							
Clause	Requirement – Test			Result – Remark		Verdict	
9	Grid voltage monitoring R157	Open	PV: 600Vdc Battery side: 600Vdc AC output: 230Vac	10min.	--	--	Output a.c. relays operated, disconnected with grid. error code“ID02”(GridUVP).Do not connect to AC mainsn.No damage,no hazards.
10	Grid voltage monitoring R 159	Short	PV: 600Vdc Battery side: 600Vdc AC output: 230Vac	10min.	--	--	Output a.c. relays operated, disconnected with grid. error code“ID01”(GridOVP).Do not connect to AC mainsn.No damage,no hazards.
11	Grid voltage monitoring R152	Open	PV: 600Vdc Battery side: 600Vdc AC output: 230Vac	10min.	--	--	Output a.c. relays operated, disconnected with grid. error code“ID02”(GridUVP).Do not connect to AC mainsn.No damage,no hazards.
12	Grid voltage monitoring R 155	Short	PV: 600Vdc Battery side: 600Vdc AC output: 230Vac	10min.	--	--	Output a.c. relays operated, disconnected with grid. error code“ID01”(GridOVP).Do not connect to AC mainsn.No damage,no hazards.
13	Grid voltage monitoring R147	Open	PV: 600Vdc Battery side: 600Vdc AC output: 230Vac	10min.	--	--	Output a.c. relays operated, disconnected with grid. error code“ID02”(GridUVP).Do not connect to AC mainsn.No damage,no hazards.
14	Grid voltage monitoring R 149	Short	PV: 600Vdc Battery side: 600Vdc AC output: 230Vac	10min.	--	--	Output a.c. relays operated, disconnected with grid. error code“ID01”(GridOVP).Do not connect to AC mainsn.No damage,no hazards.
15	RCMU detect defect R 8	Open	PV: 600Vdc Battery side: 600Vdc AC output: 230Vac	10min.	--	--	Indicate GFCI fault,error code“ID21” (GFCIDeviceFault(DC)) “ID22” (GFCIDeviceFault(AC)). Do not connect to AC mainsn.No damage,no hazards.

IEC 62109-1							
Clause	Requirement – Test				Result – Remark		Verdict
16	RCMU detect defect C171	Short	PV: 600Vdc Battery side: 600Vdc AC output: 230Vac	10min.	--	--	Indicate GFCI fault,error code“ID21” (GFCIDeviceFault(DC)) “ID22” (GFCIDeviceFault(AC)). Do not connect to AC mainsn.No damage,no hazards.
17	RCMU detect defect R 246	Short	PV: 600Vdc Battery side: 600Vdc AC output: 230Vac	10min.	--	--	Indicate GFCI fault,error code“ID21” (GFCIDeviceFault(DC)) “ID22” (GFCIDeviceFault(AC)).Do not connect to AC mainsn.No damage,no hazards.
18	RCMU detect defect R 244	Open	PV: 600Vdc Battery side: 600Vdc AC output: 230Vac	10min.	--	--	Indicate GFCI fault,error code“ID29” (ConsistentFault_GFCI , The GFCI sampling value between the master DSP and slave DSP is not consistent).Do not connect to AC mainsn. No damage,no hazards.
19	RCMU detect defect R 249	Open	PV: 600Vdc Battery side: 600Vdc AC output: 230Vac	10min.	--	--	Indicate GFCI fault,error code“ID29” (ConsistentFault_GFCI , The GFCI sampling value between the master DSP and slave DSP is not consistent). Do not connect to AC mainsn. No damage,no hazards.
20	RCMU detect defect C551	Short	PV: 600Vdc Battery side: 600Vdc AC output: 230Vac	10min.	--	--	Indicate GFCI fault,error code“ID29” (ConsistentFault_GFCI , The GFCI sampling value between the master DSP and slave DSP is not consistent). Do not connect to AC mainsn. No damage,no hazards.
21	RCMU detect defect R 920	Open	PV: 600Vdc Battery side: 600Vdc AC output: 230Vac	10min.	--	--	Indicate GFCI fault,error code“ID29”(ConsistentFault_GFCI , The GFCI sampling value between the master DSP and slave DSP is not consistent).Do not connect to AC mainsn. No damage,no hazards.

IEC 62109-1							
Clause	Requirement – Test			Result – Remark		Verdict	
22	Current sensor defect C10	Short	PV: 600Vdc Battery side: 600Vdc AC output: 230Vac	10min.	--	--	Indicate DCI fault,error code“ID18”(HwADFaultDCI) .Do not connect to AC mainsn. No damage,no hazards.
23	Current sensor defect C 51	Short	PV: 600Vdc Battery side: 600Vdc AC output: 230Vac	10min.	--	--	Indicate DCI fault,error code“ID18”(HwADFaultDCI) .Do not connect to AC mainsn.No damage,no hazards.
24	Current sensor defect C102	Short	PV: 600Vdc Battery side: 600Vdc AC output: 230Vac	10min.	--	--	Indicate DCI fault,error code“ID18”(HwADFaultDCI) .Do not connect to AC mainsn. No damage,no hazards.
25	Current sensor defect R 57	Open	PV: 600Vdc Battery side: 600Vdc AC output: 230Vac	10min.	--	--	Indicate Grid current fault,error code“ID17”(HwADFaultIGrid).Do not connect to AC mainsn. No damage,no hazards.
26	Current sensor defect R 166	Open	PV: 600Vdc Battery side: 600Vdc AC output: 230Vac	10min.	--	--	Indicate DCI fault,error code“ID18”(HwADFaultDCI) .Do not connect to AC mainsn. No damage,no hazards.
27	Grid voltage monitoring R109	Open	PV: 600Vdc Battery side: 600Vdc AC output: 230Vac	10min.	--	--	No fault. no damage.Offline –DCV is wrong.
28	Grid voltage monitoring R109	Short	PV: 600Vdc Battery side: 600Vdc AC output: 230Vac	10min.	--	--	No fault.no damage. Offline –DCV is wrong.
29	Grid voltage monitoring R203	Short	PV: 600Vdc Battery side: 600Vdc AC output: 230Vac	10min.	--	--	Indicate Grid voltage fault,error code“ID19”(HwADFaultVGrid(DC)) “ID20” (HwADFaultVGrid(AC)). Do not connect to AC mainsn. No damage,no hazards.
30	Grid voltage monitoring R240	Short	PV: 600Vdc Battery side: 600Vdc AC output: 230Vac	10min.	--	--	I Indicate Grid voltage fault,error code“ID19”(HwADFaultVGrid(DC)) “ID20”(HwADFaultVGrid (AC)).Do not connect to AC mainsn.No damage,no hazards.

IEC 62109-1							
Clause	Requirement – Test				Result – Remark		Verdict
31	Grid voltage monitoring C541	Short	PV: 600Vdc Battery side: 600Vdc AC output: 230Vac	10min.	--	--	Indicate Grid voltage fault,error code“ID20” (HwADFaultVGrid(AC)). Do not connect to AC mainsn. No damage,no hazards.
32	Grid voltage monitoring C539	Short	PV: 600Vdc Battery side: 600Vdc AC output: 230Vac	10min.	--	--	Indicate Grid voltage fault,error code“ID20” (HwADFaultVGrid(AC)). Do not connect to AC mainsn. No damage,no hazards.
33	Grid voltage monitoring C540	Short	PV: 600Vdc Battery side: 600Vdc AC output: 230Vac	10min.	--	--	Indicate Grid voltage fault,error code“ID20” (HwADFaultVGrid(AC)). Do not connect to AC mainsn. No damage,no hazards.
34	Grid voltage monitoring R904	Open	PV: 600Vdc Battery side: 600Vdc AC output: 230Vac	10min.	--	--	Indicate Grid voltage fault,error code“ID19” (HwADFaultVGrid(DC)). Do not connect to AC mainsn. No damage,no hazards.
35	Grid voltage monitoring R905	Open	PV: 600Vdc Battery side: 600Vdc AC output: 230Vac	10min.	--	--	Indicate Grid voltage fault,error code“ID19” (HwADFaultVGrid(DC)). Do not connect to AC mainsn. No damage,no hazards.
36	Grid voltage monitoring R906	Open	PV: 600Vdc Battery side: 600Vdc AC output: 230Vac	10min.	--	--	Indicate Grid voltage fault,error code“ID19” (HwADFaultVGrid(DC)). Do not connect to AC mainsn. No damage,no hazards.
37	ISO detect defect R 132	Short before start-up	PV: 600Vdc Battery side: 600Vdc AC output: 230Vac	10min.	--	--	Indicate ISO fault,error code“ID42”(PvIsoFault). Do not connect to AC mainsn. No damage,no hazards.
38	ISO detect defect R 77	Short before start-up	PV: 600Vdc Battery side: 600Vdc AC output: 230Vac	10min.	--	--	Indicate ISO fault,error code“ID42”(PvIsoFault). Do not connect to AC mainsn. No damage,no hazards.
39	ISO detect defect R 125	Short before start-up	PV: 600Vdc Battery side: 600Vdc AC output: 230Vac	10min.	--	--	Indicate ISO fault,error code“ID42” (PvIsoFault). Do not connect to AC mainsn. No damage,no hazards.

IEC 62109-1							
Clause	Requirement – Test				Result – Remark		Verdict
40	ISO detect defect R 136	Short before start-up	PV: 600Vdc Battery side: 600Vdc AC output: 230Vac	10min.	--	--	Indicate ISO fault,error code“ID42”(PvIsoFault).Do not connect to AC mainsn.Q14 damage,no hazards.
41	ISO detect defect C705	Short before start-up	PV: 600Vdc Battery side: 600Vdc AC output: 230Vac	10min.	--	--	Indicate ISO fault,error code“ID42”(PvIsoFault). Do not connect to AC mainsn. No damage,no hazards.
42	ISO detect defect C630	Short before start-up	PV: 600Vdc Battery side: 600Vdc AC output: 230Vac	10min.	--	--	Indicate ISO fault,error code“ID42”(PvIsoFault).Do not connect to AC mainsn.No damage,no hazards.
43	DSP communication defect R481	Short	PV: 600Vdc Battery side: 600Vdc AC output: 230Vac	10min.	--	--	Indicate SCI fault,error code“ID154” (SciCommLose(AC)). Do not connect to AC mainsn. Q26 damage,no hazards.
44	DSP communication defect R484	Short	PV: 600Vdc Battery side: 600Vdc AC output: 230Vac	10min.	--	--	Indicate SCI fault,error code“ID153” (SciCommLose(DC)). Do not connect to AC mainsn. Q25 damage,no hazards.
supplementary information							
See technical documentation.							

7.3.6.3.3 TABLE: protective equipotential bonding ;					P
Measured between:	Test current (A)	Voltage drop (V)	Resistance (mΩ)	result	
AC connector earthing pin to furthest point of earthed metal enclosure	32	0.25	8	Pass	
supplementary information					

7.3.6.3.7 TABLE: touch current measurement				P
Measured between:	Measured (mA)	Limit (mA)	Comments/conditions	
At metal enclosure	AC 2.3	AC 3.5 / DC 10	PE disconnected	
Supplementary information: Max. MPPT Voltage supply input, 1.1Un AC mains connection.				

IEC 62109-1						
Clause	Requirement – Test	Result – Remark				Verdict
<b>7.3.7</b>	<b>TABLE: clearance and creepage distance measurements</b>					
clearance cl and creepage distance dcr at / of:	Up (V)	U r.m.s. (V)	required cl (mm)	cl (mm)	required dcr (mm)	dcr (mm)
Power board						
PV+ to PE: BI	4000	1000Vdc 230Vac	3.6	5.28	5.0	5.28
Live part to PE (C63): BI	4000	1000Vdc 230Vac	3.6	6.30	5.0	6.30
Live part to PE (R136): BI	4000	1000Vdc 230Vac	3.6	7.02	5.0	7.02
Output board						
Live part to PE (X capacitance): BI	4000	1000Vdc 230Vac	3.6	5.33	5.0	5.33
Live part to PE (CY13): BI	4000	1000Vdc 230Vac	3.6	5.99	5.0	5.99
Live part to PE (CY17): BI	4000	1000Vdc 230Vac	3.6	6.56	5.0	6.56
Communication board						
Live part to SELV (T1 pin12 - pin 15): RI	4000	1000Vdc 230Vac	5.5	11.65	10.0	11.65
Primary to Secondary (C185): RI	4000	1000Vdc 230Vac	5.5	7.97	10.0	11.70
Live part to Secondary : BI	4000	1000Vdc 230Vac	5.5	7.40	5.0	7.40
EUT						
Live part to PE (C63): BI	4000	1000Vdc 230Vac	3.6	7.81	5.0	7.81
Live part to Enclosure: BI	4000	1000Vdc 230Vac	3.6	11.06	10.0	17.59
Live part to Cover: BI	4000	1000Vdc 230Vac	3.6	15.5	10.0	36.9
Circuits Definition:						
Communication Circuits: DVC-A			PV Circuits: DVC-C			
Battery circuits: DVC-A			AC mains / Grid Circuits: DVC-C			
Supplementary information:						
PV supply circuits = O.V.C II, AC mains circuits = O.V.C. III, DC Power Supply Voltage = O.V.C II. PD = PD2 (inside) (IP65), MG = IIIa/b, Altitude = 2000m						

IEC 62109-1			
Clause	Requirement – Test	Result – Remark	Verdict

7.3.7	TABLE: distance through insulation measurement				
distance through insulation di at/of:	U r.m.s. (V)	test voltage (V)	required di (mm)	di (mm)	
Bobbin in transformer (BI)	DC 1000V or AC 230/400V	2120	0.2	1.0	
Optical coupler <sup>1)</sup> (RI)	DC 1000V or AC 230/400V	4240	0.4	0.6	

Note(s): <sup>1)</sup> Certificated components.

7.5	TABLE: electric strength measurements, impulse voltage test and partial discharge test				P
test voltage applied between:	test voltage (V)	impulse withstand voltage (V)	partial discharge extinction voltage (V)	result	
Input to metal chassis (BI)	2120	6000	--	Pass	
Output to metal chassis (BI)	2120	6000	--	Pass	
Input to Comm. part (DI)	4240	8000	--	Pass	
Output to Comm. part (DI)	4240	8000	--	Pass	

9.2	TABLE: Limited power sources					N/A
Circuit output tested:						
Note: Measured Uoc (V) with all load circuits disconnected:						
Components	Sample No.	Uoc (V)	I <sub>sc</sub> (A)		VA	
			Meas.	Limit	Meas.	Limit
--	--	--	--	--	--	--
supplementary information:						
Sc=Short circuit, Oc=Open circuit						

IEC 62109-1			
Clause	Requirement – Test	Result – Remark	Verdict

14	TABLE: list of critical components					P
object/part No.	manufacturer/ trademark	type/model	technical data	standard	mark(s) of conformity1)	
PV connector	Amphenol Industrial operations	PV-ADBP4-S2/6-UR; PV-ADSP4-S2/6-UR	1000Vdc, 39A, Max. 108°C, IP68	EN 50521	TUV R60028286 R60087448	
alternative	Phoenix Contact GmbH & Co.kg	PV-FT-CF-C; PV-FT-CM-C	1000Vdc, 40A, Max.85°C, IP65	DIN EN 50521	TUV R60029159	
alternative	Stäubli Electrical Connectors Ltd.	MC4 Series	1000Vdc, 39A, Max. 90°C, IP68	EN 50521	TUV R60028286 R60087448	
alternative	Amphenol Technology Co., Ltd	H4-RH Bulkhead	1000Vdc, 39A, Max. 90°C, IP68	EN 50521	TUV 17011847012	
DC switch	SANTON	XBE+3410-2-D	16A 1000V/50A 500V/4POLE	EN 60947	TUV R50423069;	
Varistor (MOV1, MOV2, MOV3, MOV4)	LITTELFUSE	V1000LA160BP	1000VAC/360J/ Φ20mm	UL 1449	UL E320116	
alternative	TDK Co., Ltd.,(Chilisin Electronics Gorp)	B72220S0511K101	510VAC/511K/P=10.0mm	IEC 60068/ IEC 61051	VDE 40027582	
Y1 capacitor Input&power board:(C1, C3, C4, C7, C17, C18, C19, C20, C21, C23, C24, C29, C37, C38, C39, C40, C43, C44, C62) control board : (C184, C185, C192, C193, C194, C195, C196, C197, C218, C340, C732, C733, C747)	Samwha capacitor Co.,Ltd	SDE2G472M15 BW1	Y1/4.7nF/400VA C/P10.0/ Y5V/ Max.125°C	EN 60384-14 IEC 60384-14	VDE 40015805	
Y2 capacitor: Output board: (CY1, CY2, CY3, CY4, CY5, CY6, CY7, CY8, CY9, CY10,	XiaMen FARATRONIC Co.,Ltd	C43Q1103K40C450	Y2/10nF/300VA C/13*12*6.0	UL 60384-14	UL E186600	



IEC 62109-1			
Clause	Requirement – Test	Result – Remark	Verdict

14	TABLE: list of critical components					P
object/part No.	manufacturer/ trademark	type/model	technical data	standard	mark(s) of conformity1)	
CY11, CY12, CY13, CY14, CY15, CY16, CY17, CY18, CY19, CY20, CY21)						
BUS-Capacitor Input&power board: (EC1, EC2, EC3, EC4, EC5, EC6, EC7, EC8, EC9, EC10, EC11, EC12	Sam Young Electronics Co., Ltd.	TLS550VS470( M)(Φ35x60L)	470uF/550V/Φ3 5*60/3000H	IEC/EN 62109-1 IEC/EN 62109-2 IEC/EN 62477	Tested within appliance	
alternative	Nichicon Co., Ltd.	LGN2L471MEL ANH	470uF/550V/Φ3 5*60/3000H	IEC/EN 62109-1 IEC/EN 62109-2 IEC/EN 62477	Tested within appliance	
BUS-Capacitor Input&power board: (C91, C92, C93, C94)	Panasonic Corporation	EZPE55117MT A	110uF,10%,550 Vdc,70C,Lead Spacing = 52.5mm*20.3m m	IEC/EN 62109-1 IEC/EN 62109-2 IEC/EN 62477	Tested within appliance	
alternative	HUA JUNG COMPONENTS CO.,LTD	EPB- 117J0600DB15 2B-FF	110uF,10%,550 Vdc,70C,Lead Spacing = 52.5mm*20.3m m	IEC/EN 62109-1 IEC/EN 62109-2 IEC/EN 62477	Tested within appliance	
Capacitor Input&power board: (C15,C16,C35, C36, C95, C96, C97, C98)	XiaMen FARATRONIC Co.,Ltd	C3D1M156KF1 2382	15uF/1100VDC/ W42*H44*T24,P =37.5,4lead	EN61071:2007 IEC 61071:2007 EN61881- 1:2011 IEC 61881- 1:2011	TUV R50266108	
Capacitor output board: (C17, C18, C30, C31, C40, C41)	TDK Co., Ltd.,	B32754S8405J 500	4.0uF/350VAC/ ±10%/22*36.5*3 1.5/2P,P=27.5	IEC/EN 62109-1 IEC/EN 62109-2 IEC/EN 62477	Tested within appliance	
Capacitor output board: (C20, C21, C22, C60, C61, C62, C82, C83, C84)	TDK Co., Ltd.,	B32924A4335M 000	3.3uF/350VAC/ ±20%/X2/22*36. 5*31.5/2P,P=27. 5	EN60384-14, IEC60384-14 UL60384-14,	ENEC-01393 UL E97863	

IEC 62109-1			
Clause	Requirement – Test	Result – Remark	Verdict

14	TABLE: list of critical components					P
object/part No.	manufacturer/ trademark	type/model	technical data	standard	mark(s) of conformity1)	
IGBT Module Input&power board: (Q21)	Vincotech Technologies	10- PG07N3A050S 5-M896F96T	50A/1200V flow3xNPC 1	UL 1557	UL E192116	
IGBT Input&power board: (Q3, Q4, Q5, Q6, Q7, Q8, Q9, Q10, Q11, Q12, Q17, Q18, Q19, Q20)	Fairchild Semiconductor Corporation	FGH40T120SM D-F155	40A/1200V/TO- 247G03	IEC/EN 62109-1 IEC/EN 62109-2 IEC/EN 62477	Tested within appliance	
MOSFET control board: (Q2,Q3)	IXYS CORPORATIO N	IXFP4N85X	NMOS/3.5A/850 V/2.5Ω/TO-220	IEC/EN 62109-1 IEC/EN 62109-2 IEC/EN 62477	Tested within appliance	
Diode Input&power board: (D7,D8, D9, D10)	ON Semiconductor	FFSH20120AD N—F155	20A/1200V/TO- 247	IEC/EN 62109-1 IEC/EN 62109-2 IEC/EN 62477	Tested within appliance	
Relay Input&power board: (RL1,RL2)	Xiamen Hong fa Electroacoustics Co., Ltd.	HF161F-W/12- HT(477)	33A/277VAC/12 VDC	IEC 61810- 1:2015 DIN EN 61810-1 (VDE 0435- 201):2015-10; EN 61810- 1:2015	VDE 40031410	
Relay output board: (RL1, RL2, RL3, RL4, RL5, RL6, RL7, RL8)	ZETTLER RELAY(XIA MEN)CO., LTD	AZSR143-1AE- 12D	43A/277VAC/12 VDC/1A	EN61810- 1:2015	TUV B0887930015	
Relay output board: (RL11, RL13, RL15, RL17)	ZETTLER RELAY(XIA MEN)CO., LTD	AZSR165-1A- 12DL	80A/690VAC/12 VDC/1H	EN61810- 1:2015	TUV B170988793008	
Relay output board: (RL9,RL10)	Xiamen Hong fa Electroacoustics Co., Ltd.	HF115F/012- 2ZS4	12Vdc/8A/250V ac	IEC 61810- 1:2015 DIN EN 61810-1 (VDE 0435-	VDE 116934	

IEC 62109-1			
Clause	Requirement – Test	Result – Remark	Verdict

14	TABLE: list of critical components					P
object/part No.	manufacturer/ trademark	type/model	technical data	standard	mark(s) of conformity1)	
				201);2015-10; EN 61810- 1:2015		
Input EMI inductor Input&power board: (L1, L2, L3, L4)	HUIZHOU BAOHUI ELECTRONICS TECHNOLOGY CO., LTD	115-18-001A	1.1mH/2.2*2P	IEC/EN 62109-1 IEC/EN 62109-2 IEC/EN 62477	Tested within appliance	
Inductor Input&power board: (L5)	SHENZHEN SPT ELECTRONICS TECHNOLOGY CO., LTD	SPT-40H10292- L	3mH NPH157060	IEC/EN 62109-1 IEC/EN 62109-2 IEC/EN 62477	Tested within appliance	
Boost Inductor Input&power board:	HUIZHOU BAOHUI ELECTRONICS TECHNOLOGY CO., LTD	NPF250060- 18*3	914uh NPF250060	IEC/EN 62109-1 IEC/EN 62109-2 IEC/EN 62477	Tested within appliance	
alternative	SHENZHEN Spitzer ELECTRONICS CO., LTD	NPF250060- 18*3	1100uh NPF250060	IEC/EN 62109-1 IEC/EN 62109-2 IEC/EN 62477	Tested within appliance	
Inv Inductor Input&power board:	HUIZHOU BAOHUI ELECTRONICS TECHNOLOGY CO., LTD	NPF250060- 18*3	876uh NPF250060	IEC/EN 62109-1 IEC/EN 62109-2 IEC/EN 62477	Tested within appliance	
alternative	SHENZHEN Spitzer ELECTRONICS CO., LTD	NPF250060- 18*3	1030uh NPF250060	IEC/EN 62109-1 IEC/EN 62109-2 IEC/EN 62477	Tested within appliance	
output EMI inductor output board: (L2)	SHENZHEN SPT ELECTRONICS TECHNOLOGY CO., LTD	SPT-64H10332- L	1mH Min/60A/T64x40 x20mm	IEC/EN 62109-1 IEC/EN 62109-2 IEC/EN 62477	Tested within appliance	
-coil	WUXI JUFENG COMPOUND LINE CO LTD	MW 75-C	130°C	UL 1446	UL E206882	
alternative	SHENZHEN SPT ELECTRONICS TECHNOLOGY	SPT-64H10332- L	1mH Min/60A/T64x40 x20mm	IEC/EN 62109-1 IEC/EN 62109-2 IEC/EN 62477	Tested within appliance	

IEC 62109-1			
Clause	Requirement – Test	Result – Remark	Verdict

14	TABLE: list of critical components					P
object/part No.	manufacturer/ trademark	type/model	technical data	standard	mark(s) of conformity1)	
	CO., LTD					
-coil	TAI-I COPPER (GUANZHOU) CO LTD	MW 75-C	130°C	UL 1446	UL E234896	
output EMI inductor output board: (L1)	SHENZHEN SPT ELECTRONICS TECHNOLOGY CO., LTD	SPT-50H10331- L	1.8mH Min/30A/T50x40 x20mm	IEC/EN 62109-1 IEC/EN 62109-2 IEC/EN 62477	Tested within appliance	
-coil	WUXI JUFENG COMPOUND LINE CO LTD	MW 75-C	130°C	UL 1446	UL E206882	
alternative	SHENZHEN SPT ELECTRONICS TECHNOLOGY CO., LTD	SPT-50H10331- L	1.8mH Min/30A/T50x40 x20mm	IEC/EN 62109-1 IEC/EN 62109-2 IEC/EN 62477	Tested within appliance	
-coil	TAI-I COPPER (GUANZHOU) CO LTD	MW 75-C	130°C	UL 1446	UL E234896	
Transformer control board : (T3)	HUIZHOU BAOHUI ELECTRONICS TECHNOLOGY CO., LTD	115-19-067A	EE13V(16/21:21 ) DIP	IEC/EN 62109-1 IEC/EN 62109-2 IEC/EN 62477	Tested within appliance	
-coil	SHANGHAI ASIA PACIFIC ELECTRIC CO LTD	MW 75-C	130°C	UL 1446	UL E214423	
-alternative	PACIFIC ELECTRIC WIRE & CABLE (SHENZHEN) CO LTD	MW 75-C	130°C	UL 1446	UL E201757	
-alternative	SUZHOU TAIHU ELECTRIC ADVANCED MATERIAL CO LTD	MW 28-C	130°C	UL 1446	UL E228349	
Transformer control board : (T1)	HUIZHOU BAOHUI ELECTRONICS TECHNOLOGY	ETD39(TRANS FORMER)	0.46mH/ETD39/ R40 DIP	IEC/EN 62109-1 IEC/EN 62109-2 IEC/EN 62477	Tested within appliance	

IEC 62109-1			
Clause	Requirement – Test	Result – Remark	Verdict

14	TABLE: list of critical components					P
object/part No.	manufacturer/ trademark	type/model	technical data	standard	mark(s) of conformity1)	
	CO., LTD					
-coil	SHANGHAI ASIA PACIFIC ELECTRIC CO LTD	MW 75-C	130°C	UL 1446	UL E214423	
-alternative	PACIFIC ELECTRIC WIRE & CABLE (SHENZHEN) CO LTD	MW 75-C	130°C	UL 1446	UL E201757	
-alternative	SUZHOU TAIHU ELECTRIC ADVANCED MATERIAL CO LTD	MW 28-C	130°C	UL 1446	UL E228349	
IC control board : (U1,U2,U3)	TEXAS INSTRUMENTS	AMC1200BDW VR	AMC1200BDW V/SOIC-8	UL1577	UL E181974	
IC control board : (U39)	TEXAS INSTRUMENTS	TMS320F28004 9PZS	Microcontroller/ LQFP100	IEC/EN 62109-1 IEC/EN 62109-2 IEC/EN 62477	Tested within appliance	
IC control board : (U37)	TEXAS INSTRUMENTS	TMS320F28075 PTP	Digital Signal Controller/HLQF P-176	IEC/EN 62109-1 IEC/EN 62109-2 IEC/EN 62477	Tested within appliance	
IC control board : (U13)	SHENZHEN PANGO MICROSYSTE MS CO., LTD	PK03004_PGC 2KG_LPG144	CPLD IO 112/4 3.3V /LPG144	IEC/EN 62109-1 IEC/EN 62109-2 IEC/EN 62477	Tested within appliance	
Optocoupler control board : (U23)	TEXAS INSTRUMENTS	ISO7721	Digital Isolators/SOP-8	UL 1577	UL E181974	
All PCB	SHANTOU LUCKY STAR PCB CO LTD	WS888	130°C, V-0	UL 796	UL E301869	
alternative	SHENZHEN GLORYSKY ELECTRONICS CO LTD	GS-M	130°C, V-0	UL 796	UL E257384	
Internal wiring (DC-in)	All accepted	ALL AWG#12 AWG#10	1000V 105°C	UL 2885	UL E341104	

IEC 62109-1			
Clause	Requirement – Test	Result – Remark	Verdict

14 TABLE: list of critical components					P
object/part No.	manufacturer/ trademark	type/model	technical data	standard	mark(s) of conformity <sup>1)</sup>
Internal wiring (AC-out)	All accepted	AWG#6	1000V 105°C	UL 2885	UL E341104
Surface cover	All accepted	AL 5052 thickness=2.0m m	564.8mm*465m m*145mm	IEC/EN 62109-1 IEC/EN 62109-2 IEC/EN 62477	Tested within appliance
Heat-sink (the rear side of enclosure)	All accepted	AL 6063 T5	415mm*212mm *73.3mm	IEC/EN 62109-1 IEC/EN 62109-2 IEC/EN 62477	Tested within appliance
Metal Enclosure	All accepted	AL 5052 thickness=2.0m m	Min. thickness:2.0	/	/
SPD output board: (SPD1,SPD2,S PD3,SPD4)	SICHUAN ZHONGGUANG HI-TECH CO., LTD	ZGGS20- 670PVh1b1	ZGGS20- 670PVh1b1 /510VAC/670VD C /10kA (8/20s)	IEC/EN 62109-1 IEC/EN 62109-2 IEC/EN 62477	Tested within appliance

1) an asterisk indicates a mark which assures the agreed level of surveillance

**List of test equipment used:**

No.	Equipment name	Manufacture	Serial No.	Calibration Data	Usage
1	Simulation of ac power supply	WLPA-33-1000KVA	BZ-DGD-L001	--	√
2	Solar IV simulator	WDGC-1000KW	BZ-DGD-L002	--	√
3	Programmable ac load	ACLT-38160H	BZ-DGD-L003	--	√
4	Power analyser	PW6001-16	BZ-DGD-L025	2021\3\04	√
5	Oscilloscope	MSO4054B	BZ-DGD-L028	2021\3\04	√
6	Heating Recorder	LR8400-21	BZ-DGD-L032	2020\8\28	√
7	Hi-Pot & IR tester	Chroma 19032	BZ-DGD-L066	2021\3\04	√
8	Noise meter	TES-1357	BZ-DGD-L029	2021\3\06	√
9	Digital Caliper	LS160	BZ-DGD-L048	2020\07\02	√
10	Testing Finger B	AUTO-B	BZ-DGD-L011	2020\11\1	√
11	DC Electronic Load	IT8511+	BZ-DGD -L027	2020\10\31	√
12	Pull and push	2P-1000	BZ-DGB-L080	2020\8\28	√
13	Electronic Scale	TCS-300	BZ-DGB-L020	2020\07\02	√
14	Thermostat	16m <sup>3</sup>	BZ-DGD-L015	2020\07\02	√
15	Surge generator	HCWG 70	BZ-DGE-L036	2020\5\6	√

- End of Test Report -